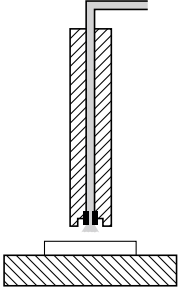
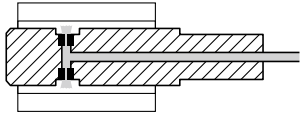
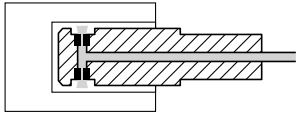
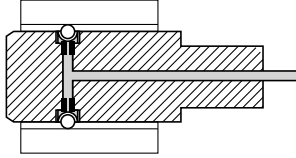
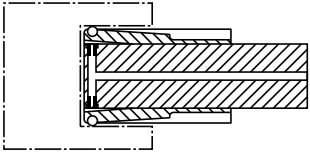
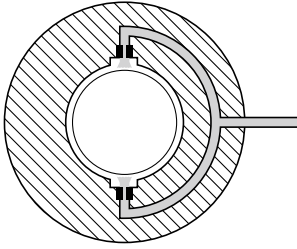
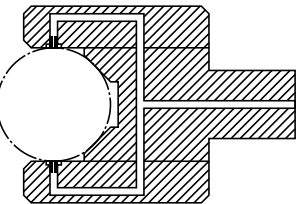
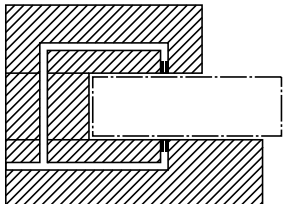
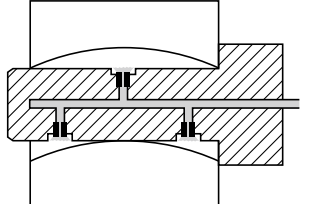
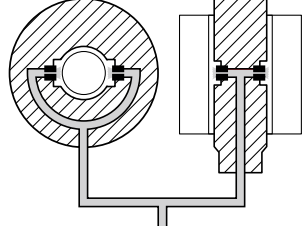
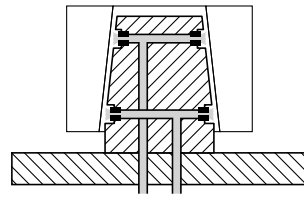
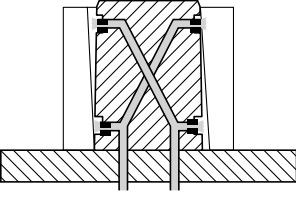
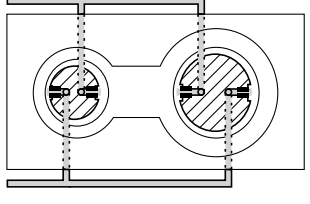
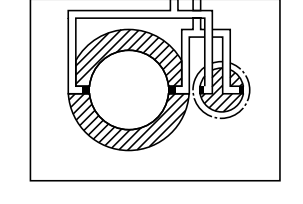
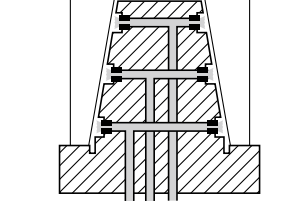
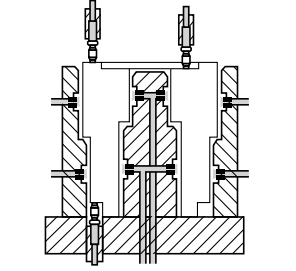

空気マイクロメータ測定例  
Measurement examples of  
Air micrometer

各種の測定ヘッドを用いて下記のような項目の測定ができます。  
Measurement as below can be applied by using various measuring heads.

 <p>1. 厚さ測定 For thickness</p>	 <p>2. 内径測定 (通し穴) For internal dia.(through hole)</p>	 <p>3. 内径測定 (止まり穴) For internal dia.(blind hole)</p>	 <p>4. 内径測定 (ボールコンタクト式) For internal dia.(Ball contact type)</p>
 <p>5. 内径測定 (リーフ式) For internal dia.(plate spring type)</p>	 <p>6. 外径測定 (リング式) For external dia.(Ring type)</p>	 <p>7. 外径測定 (ハサミ式) For external dia.(Caliper type)</p>	 <p>8. 厚さ測定 For thickness</p>
 <p>9. 真直度測定 For straightness</p>	 <p>10. マッチング (穴と軸のはめあいすきま) 測定 For mating between bore and shaft</p>	 <p>11. テーパー測定 For conicity of inner cone</p>	 <p>12. 直角度測定 For perpendicularity</p>
 <p>13. 心間距離 (ピッチ) 測定 For spacing between separate cylindrical bores</p>	 <p>14. 心間距離 (ピッチ) 測定 (特殊) For spacing between separate cylindrical bores (special purpose)</p>	 <p>15. テーパー及び基準径測定 For conicity, form &amp; basic diam.</p>	 <p>16. 多点測定 For multi-places</p>