



ISSOKU

# PRECISION MACHINE PARTS

## 精密機械部品

BALL SCREW/ROLLED BALL SCREW/LEAD SCREW  
LINEAR POSITIONING TABLE/SPINDLE UNIT

ボールねじ/転造ボールねじ/送りねじ/直動テーブル/精密スピンドルユニット

# ボールねじの選定 SELECTION OF BALL SCREW

## ねじ径とリードの組合せ [Combination of nominal dia and nominal lead]

単位:mm Unit:mm

ねじ径 Dia	リ ー ド Lead														
	1	1.5	2	2.5	3	4	5	6	8	10	12	15	16	20	25
4	◎														
5	○														
6	◎	○	◎												
8	◎	○	◎		○	○	◎	○	◎						
10	○	○	◎	○	○	◎	◎	○	○	◎					
12	○		◎	○	○	◎	◎	○	○	◎			○	◎	
14	○		◎	○	○	◎	◎	○	○				○		
15			○			◎	◎			◎		◎		◎	
16			◎	○	○	◎	○	○	○				◎	○	
18			○			○		○							
20			○		○	○	◎	○	○	◎	○		○	◎	
25			○		○	○	○	○	○	○	○		○	○	○
28						○	○	○							
32						○	○	○	○						
36						○	○	○	○						
40						○	○	○	○						

- ISSOKUでは表中の◎、○のサイズを製作しています。
- ◎のサイズは標準ボールねじとしてC3等級品を在庫してありますので短納期、廉価にてご利用いただけます。
- この表以外のサイズも製作しています(特殊リード、インチサイズ)。

- ISSOKU produce ◎ ○ in the chart.
- ISSOKU has stock grade C3 ball screws marked ◎ in the chart, for quick delivery with low price.
- Other size can be also made (non standard lead inch size etc).

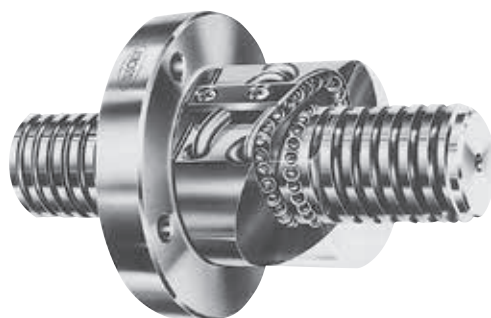

## 軸方向すきま [Axial clearance]

### 1) 軸方向すきま Axial clearance

単位:mm Unit:mm

軸方向すきま記号 Axial clearance mark	Z	T	S	N
軸方向すきま量 Axial clearance	0	0.005以下	0.020以下	0.050以下

### 2) 精度等級と軸方向すきま Accuracy grade and axial clearance

軸方向すきま記号 Axial clearance mark	Z	T	S	N	
精度等級 Accuracy grade	C0	C0Z	C0T		
	C1	C1Z	C1T		
	C2	C2Z	C2T	C2S	
	C3	C3Z	C3T	C3S	C3N
	C5	C5Z	C5T	C5S	C5N

## ねじ軸の製作範囲 [Production range of screw shaft]

表は標準の作業で製作できるねじ軸の最大長さを示します。製作範囲を超える場合はご相談下さい。

Maximum length with standard procedure is shown in below. Please ask for out of this range.

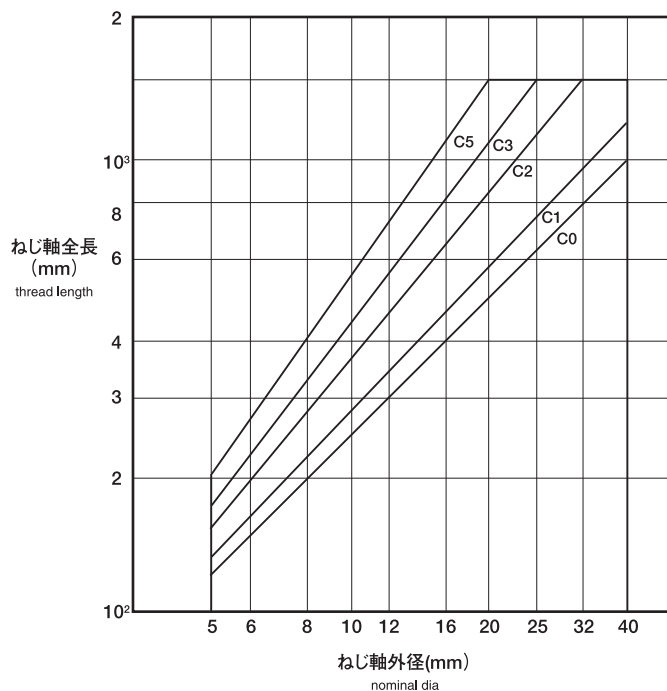

潤滑と保守 [Lubrication and maintenance]

グリス潤滑:リチウム石けん基系 アルバニヤ S1  
オイル潤滑:タービン油 ISO VG68

Grease lubrication: Lithium sope based grease Alvania S1  
Oil lubrication: Turbine oil ISO VG 68

潤滑方法	定期点検	点検内容	保守内容
グリース	稼働初期 1~2ヶ月	汚 れ 異物混入	通常6ヶ月~1年 又は1000~2000時 間で補給
オイル (自動給油)	1週間毎	油 量	油切れにならないこと

Method	Periodic inspection	Check item	Maintenance item (replenish interval)
Grease	Initially 1-2 months	Dirt particles contamination entry of chip	Replenish normally with the interval of 6-12 months or after 1000-2000 hours usage
Oil (automatic lubrication)	Every week	Quantity of oil	Never be short of oil

位置決め用ボールねじの代表移動量誤差と変動の許容値 [Cumulative representative lead errors and travel variations (permissible values)]

単位:µm unit:µm

精度等級 及び項目 ねじ部 有効長さ (mm) Effective thread length		C0		C1		C2		C3		C5	
		代表移動量 誤差 Cumulative representative lead error	変動 <sup>(1)</sup> Travel variation <sup>(1)</sup>	代表移動量 誤差 Cumulative representative lead error	変動 <sup>(1)</sup> Travel variation <sup>(1)</sup>	代表移動量 誤差 Cumulative representative lead error	変動 <sup>(1)</sup> Travel variation <sup>(1)</sup>	代表移動量 誤差 Cumulative representative lead error	変動 <sup>(1)</sup> Travel variation <sup>(1)</sup>	代表移動量 誤差 Cumulative representative lead error	変動 <sup>(1)</sup> Travel variation <sup>(1)</sup>
を 超え above	以 下 include										
—	125	3	3	3.5	5	5	7	8	8	18	18
125	200	3.5	3	4.5	5	7	7	10	8	20	18
200	315	4	3.5	6	5	8	7	12	8	23	18
315	400	5	3.5	7	5	9	7	13	10	25	20
400	500	6	4	8	5	10	7	15	10	27	20
500	630	6	4	9	6	11	8	16	12	30	23
630	800	7	5	10	7	13	9	18	13	35	25
800	1000	8	6	11	8	15	10	21	15	40	27
1000	1250	9	6	13	9	18	11	24	16	46	30
1250	1600	11	7	15	10	21	13	29	18	54	35

注<sup>(1)</sup> ナットの有効移動距離又はねじ軸のねじ部有効長さに対する変動

Note<sup>(1)</sup> Travel variation in respect to the effective travelling distance of nut or to the effective thread length of screw shaft.

変 動 (許容値) [Travel variations (permissible values)]

単位:µm unit:µm

精度等級 Accuracy grade	C0		C1		C2		C3		C5	
項 目 Item	変 動 Travel variation300 <sup>(2)</sup>	変 動 Travel variation2π <sup>(3)</sup>	変 動 Travel variation300 <sup>(2)</sup>	変 動 Travel variation2π <sup>(3)</sup>	変 動 Travel variation300 <sup>(2)</sup>	変 動 Travel variation2π <sup>(3)</sup>	変 動 Travel variation300 <sup>(2)</sup>	変 動 Travel variation2π <sup>(3)</sup>	変 動 Travel variation300 <sup>(2)</sup>	変 動 Travel variation2π <sup>(3)</sup>
許容値 Permissible value	3.5	3	5	4	6	5	8	6	18	8

注<sup>(2)</sup> ねじ軸のねじ部有効長さの間に任意にとった300mmに対する変動。

<sup>(3)</sup> ねじ軸のねじ部有効長さの間の1回転 (2π rad) に対する変動。







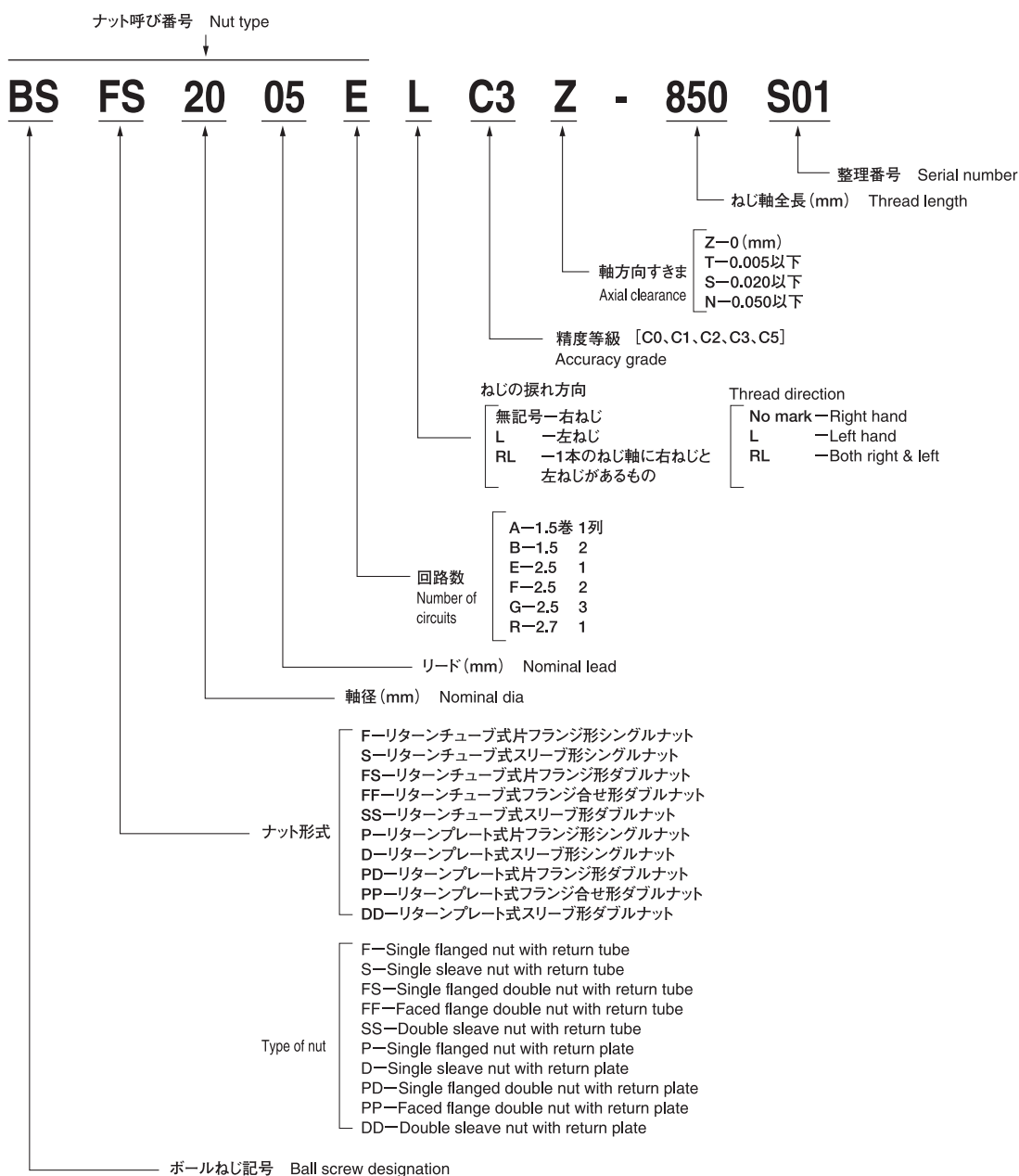
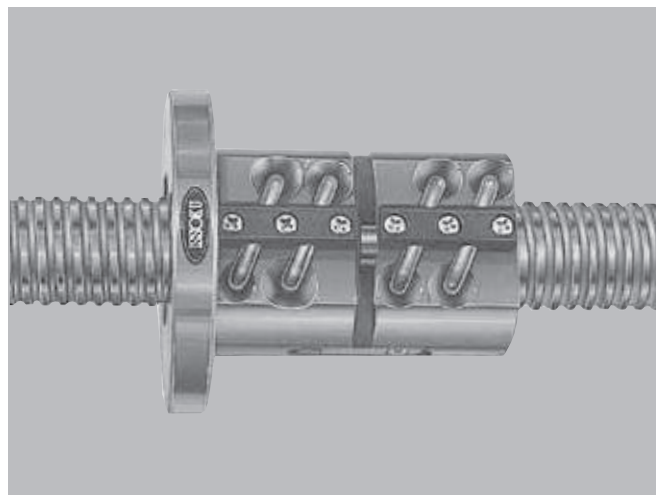

Note<sup>(2)</sup> Travel variation in respect to 300mm taken arbitrarily within the effective thread length of screw shaft.

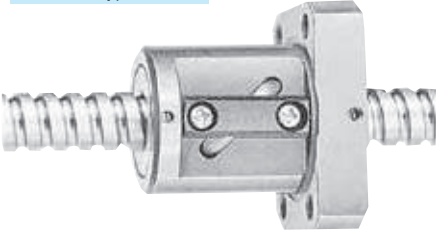
Note<sup>(3)</sup> Travel variation in respect to one arbitrary revolution (2π rad) within the effective thread length of screw shaft.

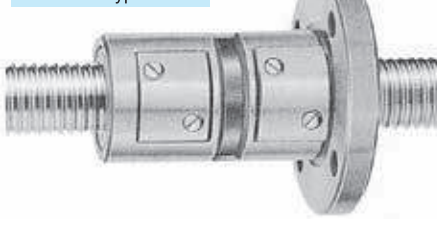
# ボールねじ呼び番号 IDENTIFICATION NUMBERS

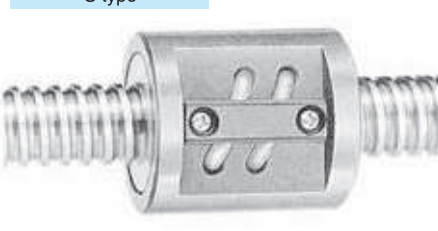

# ボールねじナット形式 TYPE OF NUT

リターンチューブ方式 Return tube type	特 長 Advantages	リターンプレート方式 Return plate type
<p><b>F型ナット</b> F type</p> 	<p>ナット1個の最も簡単なタイプです。通常わずかな軸方向すきまで使用します。又、オーバーサイズボールを使用することにより、軽予圧を与え軸方向すきまをゼロにすることもできます。ナットの取付けはフランジ面のボルト穴を使用します。</p> <p>Simple single nut type. Normally used with axial clearance. Light preload can be applied with over sized ball. Use bolt holes on flange for mounting.</p>	<p><b>P型ナット</b> P type</p> 
<p><b>FS型ナット</b> FS type</p> 	<p>2個のナットの間には予圧量分の厚いスペーサを入れ軸方向すきまを除去します。又、予圧を与えることにより剛性を高めることができます。ナットの取付けはフランジ面のボルト穴を使用します。</p> <p>Put spacer between two nuts to give preload for rigidity. Use bolt holes on flange for mounting.</p>	<p><b>PD型ナット</b> PD type</p> 
<p><b>FF型ナット</b> FF type</p> 	<p>2個のナットのフランジ面の間にスペーサを入れ予圧を与えます。FS型・PD型と同様に軸方向すきまを除去し、剛性を高めることができます。ナットの取付けはフランジ面のボルト穴を使用します。(ナット寸法についてはISSOKUまでお問い合わせ下さい。)</p> <p>Put spacer between two flange face. As FS and PD, axial clearance is removed and preload for rigidity. Use bolt holes on flange for mounting. (Please ask ISSOKU for dimation of nut)</p>	<p><b>PP型ナット</b> PP type</p> 
<p><b>S型ナット</b> S type</p> 	<p>円筒型ナット1個のもので、F型・P型と同様に通常わずかな軸方向すきまで使用しますがオーバーサイズボールにより軽予圧を与えることもできます。ナットの取付けは円筒面に設けたキーとナット両端面で固定します。</p> <p>Normally used with axial clealance as F and P. Light preload can be applied with over sized ball. Key way and both ends are used for mounting.</p>	<p><b>D型ナット</b> D type</p> 
<p><b>SS型ナット</b> SS type</p> 	<p>円筒型ナットを2個使用し、中間にスペーサを入れ予圧を与えます。ナットの取付けは円筒面に設けたキーとナット両端面で固定します。</p> <p>Put spacer between two nut for preload. Key way and both ends are used for mounting.</p>	<p><b>DD型ナット</b> DD type</p> 

# 標準シリーズ STANDARD BALL SCREWS

## 特徴 [Features]

- [1] 永年のねじゲージ製造技術を基に全館恒温、恒湿に管理された工場にて製作しております。
  - [2] ねじゲージのJIS表示認定工場であり、高精度、高品質により高い信頼を受けております。
  - [3] 短納期、即納品、豊富な種類、ストロークを用意しました。
  - [4] 精度等級はJIS B 1192に基づき、C3級とし、軸方向すきまは0.005mm以下(記号T)を選定しております。
  - [5] ナット両端にはワイパーシール(樹脂製)を内蔵しています。より完璧な防塵にはカバー等が必要ですので当社までご相談下さい。
- [1] ISSOKU is producing Precision Ball Screws in the temperature and humidity controlled factory, based on the traditional production technology of high precision Thread Gauges.
  - [2] ISSOKU has been allowed to mark "JIS (Japanese industrial Standard)" mark for high accuracy and high quality of its products.
  - [3] ISSOKU is promoting prompt and short delivery from stock with wide variations in sizes and strokes.
  - [4] Standard Precision Ball Screws are supplied with C3 accuracy grade and Max. 0.005mm (mark T) axial clearance, according to JIS B 1192.
  - [5] Plastic seals (synthetic resin made) are prepared at both nut ends. For more complete dust protection, covers and other means of protection are required. Please ask ISSOKU.

## 軸径と呼びリードの組合せ [Combination of nominal dia. and nominal lead.]

単位:mm unit:mm

軸径 Nominal dia.	呼びリード Nominal lead								
	1	2	4	5	8	10	15	16	20
4	●								
6	○ ●	○ ●							
8	○ ●	○ ●		●	●				
10		○ ●	○ ●	○ ●		○ ●			
12		○ ●	○ ●	○ ●		○ ●			○ ●
14		○ ●	○	○ ●					○ ●
15			●	●		○ ●	●		○ ●
16		●	○					○	
20				●		○ ●			○ ●

- :軸端完成品 Finished shaft ends
- :軸端末加工品 Un-worked shaft ends

## 形式 [Type]

- BSP 完成品 プレート式
- BSF 完成品 チューブ式
- GPR 軸端末加工品 プレート式
- GTR 軸端末加工品 チューブ式

- BSP Plate type standard series
- BSF Tube type standard series
- GPR Plate type series with un-worked shaft ends
- GTR Tube type series with un-worked shaft ends

## 呼び番号 [Identification numbers]

**BSF 12 05 E C3 T-380 S01**

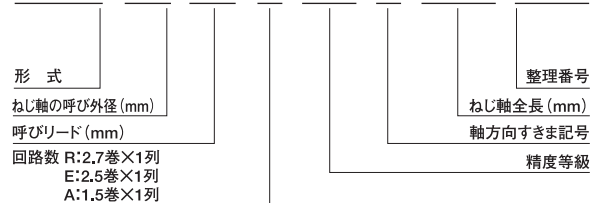

**BSF 12 05 E C3 T-380 S01**

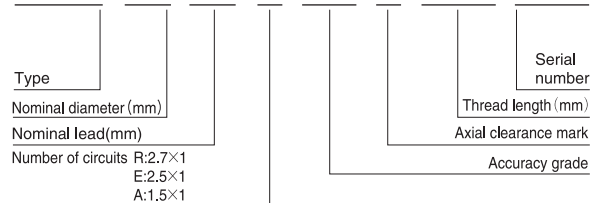

# 軸端完成品 FINISHED SHAFT ENDS

精度等級 JIS C3級  
Accuracy grade JIS C3

軸方向すきま 0.005mm以下  
Axial clearance Max. 0.005mm include

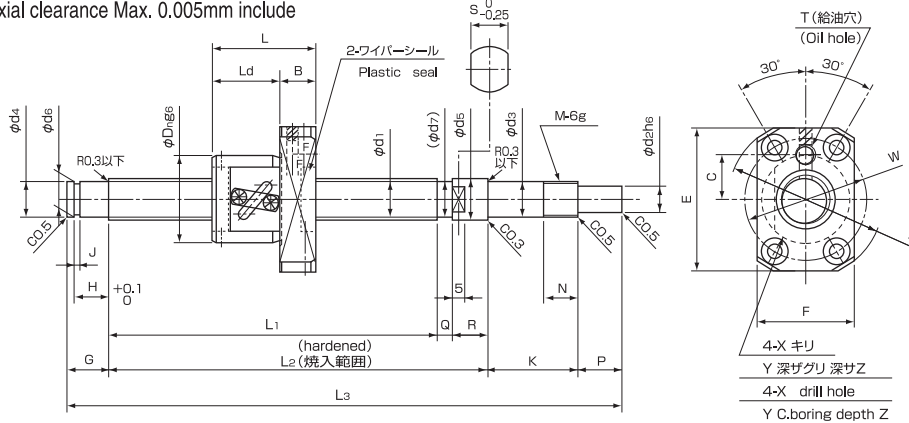

# 軸端完成品 FINISHED SHAFT ENDS

精度等級 JIS C3級  
Accuracy grade JIS C3

軸方向すきま 0.005mm以下  
Axial clearance Max. 0.005mm include

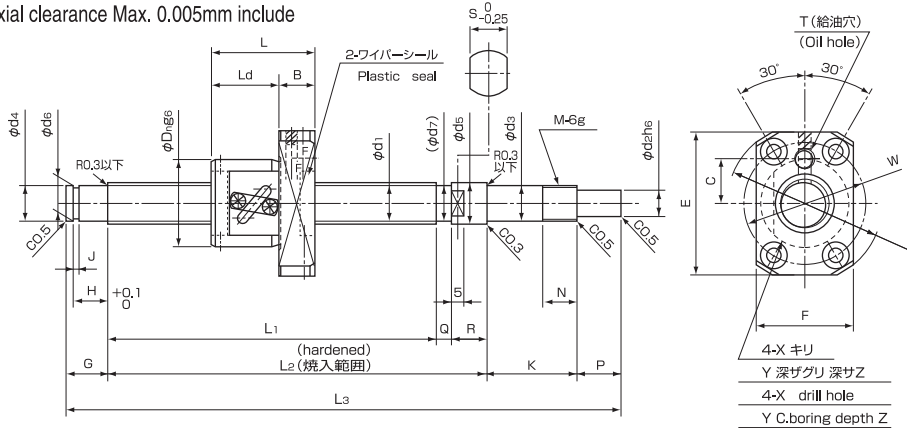

- I 材質 Material  
軸、ナット:SCM415H  
Shaft, Nut:JIS SCM415H
- II 特別仕様品についてはご相談下さい。  
φ4~φ40、長さ1500mm以下  
ステンレス製ボールねじも製作いたします。  
Other specifications are also available.  
Dia.φ4~φ40,Length up to 1500mm Stainless ball screw is also available.
- III 基本定格荷重欄のCaは動定格、Coaは静定格を表わします。尚、この場合の単位はNとなります。  
“Ca” in Basic Load Ratings means Dynamic Load Ratings and “Coa” does Static Load Ratings. Unit in Newton.

単位:mm unit:mm

呼び番号 Identification number	軸径 Nominal dia.d1	リード Nominal lead	ストローク Stroke	ねじ軸寸法 Screw shaft dimensions																	ナット寸法 Nut dimensions													基本定格荷重(N) Basic load ratings (N)					
				L1	L2	L3	G	H	J	K	N	P	Q	R	d2	d3	d4	d5	d6	d7	S	M	Dn	A	L	Ld	B	E	F	W	C	T	X	Y	Z	Ca	Coa		
BSF1220AC3T -377 -427 -477 -527	12	20	200	302	322	377	10	7.9	0.9	+0.06 0	30	10	15	10	10	8	-0.002 -0.008	-0.004 -0.012	0 -0.09	14	7.6	9.9	12	M10 X 0.75	30	50	62	50	12	45	32	40	15	M6	4.5	8	4.5	2410	3920
			250	352	372	427																																	
			300	402	422	477																																	
			350	452	472	527																																	
BSP1402RC3T -222 -272 -322	14	2	100	140	155	222	22	9.15	1.15	+0.14 0	30	10	15	5	10	10	-0.003 -0.011	-0.004 -0.012	0 -0.09	15	9.6	12	12	M12 X 1.0	26	49	30	19	11	44	30	37	14	M6	5.5	9.5	5.4	2470	5290
			150	190	205	272																																	
			200	240	255	322																																	
BSF1404EC3T -287 -337 -387	14	4	150	205	220	287	22	9.15	1.15	+0.14 0	30	10	15	5	10	10	-0.003 -0.011	-0.004 -0.012	0 -0.09	15	9.6	11.7	12	M12 X 1.0	34	57	37	26	11	50	34	45	17	M6	5.5	9.5	5.4	4220	7150
			200	255	270	337																																	
			250	305	320	387																																	
			150	211	226	293																																	
BSF1405EC3T -293 -343 -393 -443	14	5	200	261	276	343	22	9.15	1.15	+0.14 0	30	10	15	5	10	10	-0.003 -0.011	-0.004 -0.012	0 -0.09	15	9.6	11.1	12	M12 X 1.0	34	57	41	30	11	50	34	45	17	M6	5.5	9.5	5.4	6270	11660
			250	311	326	393																																	
			300	361	376	443																																	
			200	289	304	371																																	
BSF1510EC3T -371 -471 -571 -671	15	10	300	389	404	471	22	9.15	1.15	+0.14 0	30	10	15	5	10	10	-0.003 -0.011	-0.004 -0.012	0 -0.09	15	9.6	12	12	M12 X 1.0	34	57	51	40	11	50	34	45	17	M6	5.5	9.5	5.4	6610	12540
			400	489	504	571																																	
			500	589	604	671																																	
			300	402	417	484																																	
BSF1520AC3T -484 -584 -684 -784	15	20	400	502	517	584	22	9.15	1.15	+0.14 0	30	10	15	5	10	10	-0.003 -0.011	-0.004 -0.012	0 -0.09	15	9.6	12	12	M12 X 1.0	34	57	62	50	12	50	34	45	17	M6	5.5	9.5	5.4	4230	7840
			500	602	617	684																																	
			600	702	717	784																																	
			200	257	272	339																																	
BSF1604EC3T -339 -439 -539	16	4	300	357	372	439	22	9.15	1.15	+0.14 0	30	10	15	5	10	10	-0.003 -0.011	-0.004 -0.012	0 -0.09	15	9.6	12	12	M12 X 1.0	36	59	37	26	11	53	36	47	18	M6	5.5	9.5	5.4	4640	8530
			400	457	472	539																																	
			200	284	304	371																																	
			300	384	404	471																																	
BSF1616AC3T -471 -571 -671 -771	16	16	400	484	504	571	22	9.15	1.15	+0.14 0	30	10	15	10	10	10	-0.003 -0.011	-0.004 -0.012	0 -0.09	15	9.6	12	12	M12 X 1.0	40	63	56	44	12	56	40	51	20	M6	5.5	9.5	5.4	4380	8230
			500	584	604	671																																	
			600	684	704	771																																	
			200	289	314	399																																	
			300	389	414	499																																	
BSF2010EC3T -399 -499 -599 -699 -799	20	10	400	489	514	599	25	10.15	1.15	+0.14 0	40	15	20	10	15	12	-0.004 -0.012	-0.004 -0.012	0 -0.11	20	14.3	17	17	M15 X 1.0	44	67	54	41	13	60	44	55	22	M6	5.5	9.5	5.4	8150	17150
			500	589	614	699																																	
			600	689	714	799																																	
			300	410	435	520																																	
BSF2020AC3T -520 -620 -720 -820 -920	20	20	400	510	535	620	25	10.15	1.15	+0.14 0	40	15	20	10	15	12	-0.004 -0.012	-0.004 -0.012	0 -0.11	20	14.3	16.5	17	M15 X 1.0	46	74	70	55	15	66	46	59	24	M6	6.6	11	6.5	6710	12640
			500	610	635	720																																	
			600	710	735	820																																	
			700	810	835	920																																	



# 軸端未加工品 UN-WORKED SHAFT ENDS

精度等級 JIS C3級  
Accuracy grade JIS C3  
軸方向すきま 0.005mm以下  
Axial clearance Max. 0.005mm include

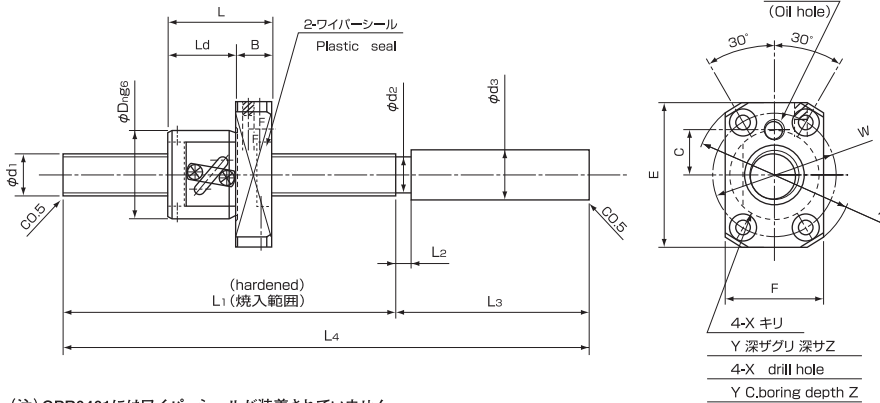

(注) GPR0401にはワイバーシールが装着されていません。  
Note- This model is not provided with a plastic seal.

- I 材質 Material  
軸、ナット:SCM415H  
Shaft, Nut:JIS SCM415H
- II 特別仕様品についてはご相談下さい。  
φ4~φ40、長さ1500mm以下  
ステンレス製ボールねじも製作いたします。  
Other specifications are also available.  
Dia.φ4~φ40,Length up to 1500mm Stainless ball screw is also available.
- III 基本定格荷重欄のCaは動定格、Coaは静定格を表わします。尚、この場合の単位はNとなります。  
“Ca” in Basic Load Ratings means Dynamic Load Ratings and “Coa” does Static Load Ratings. Unit in Newton.
- IV ご使用に際しては軸端の追加加工が必要です。軸端の加工は当社にて行うことをお奨めいたします。当社以外で追加加工を行った場合は、追加後の精度保証はいたしかねますのでご了承ください。  
Additional machining of screw shaft end is required when ball screw is used. We recommend you to do this machining to ISSOKU, because this machining is performed by other companies except ISSOKU, accuracy for such a ball screw should not be warranted by ISSOKU.

単位:mm unit:mm

呼び番号 Identification number	軸径 Nominal dia.d1	リード Nominal lead	スローク Stroke	ねじ軸寸法 Screw shaft dimensions							ナット寸法 Nut dimensions											谷径 Root dia.	BCD	回路数 巻×列 Circuits × Turn	基本定格荷重(N) Basic load ratings (N)		
				L1	L2	L3	L4	d2	d3	Dn	A	L	Ld	B	E	F	W	C	T	X	Y				Z	Ca	Coa
GPR0401RC3T-100 (注) (Note)	4	1	30	60	4	40	100	4	10	11	21	19	15	4	—	14	16	—	—	2.9	—	—	3.15	4.15	2.7X1	470	780
			80	110			150																				
GPR0601RC3T-190	6	1	100	140	3	50	140	5.2	10	13	29	20	15	5	26	19	21	—	—	3.4	6.5	3	5.3	6.15	2.7X1	630	1130
			150	190			240																				
GPR0602RC3T-200	6	2	100	150	3	50	200	4.5	10	18	34	24	19	5	31	22	26	—	—	3.4	6.5	3	4.6	6.3	2.7X1	1350	2350
			150	200			250																				
GPR0801RC3T-220	8	1	50	90	3	60	150	7.2	10	16	32	20	15	5	29	21	24	—	—	3.4	6.5	3	7.3	8.15	2.7X1	750	1520
			120	160			220																				
GPR0802RC3T-230	8	2	120	170	3	60	230	6.5	10	20	40	25	19	6	36	25	30	—	—	4.5	8	4.4	6.6	8.3	2.7X1	1690	3085
			200	250			310																				
GTR0805EC3T-240	8	5	60	120	5	60	180	6.1	10	24	44	37	29	8	40	27	34	—	—	4.5	8	4.4	6.2	8.3	2.5X1	2290	3575
			120	180			240																				
GTR0808AC3T-260	8	8	60	130	8	70	200	6.1	10	24	44	36	28	8	40	27	34	—	—	4.5	8	4.4	6.2	8.3	1.5X1	1450	2155
			120	190			260																				
GPR1002RC3T-320	10	2	100	140	5	80	220	8.5	14	23	43	29	19	10	39	27	33	12	M6	4.5	8	4.4	8.6	10.3	2.7X1	1980	3820
			200	240			320																				
GTR1004EC3T-380	10	4	100	150	5	80	230	8.1	14	26	46	34	24	10	42	28	36	14	M6	4.5	8	4.4	8.2	10.3	2.5X1	2730	4410
			250	300			380																				
GTR1005EC3T-390	10	5	100	160	5	80	240	8.1	14	26	46	40	30	10	42	28	36	14	M6	4.5	8	4.4	8.2	10.3	2.5X1	2730	4410
			250	310			390																				
GTR1010AC3T-440	10	10	100	160	7	80	240	8.1	14	26	46	40	30	10	42	28	36	14	M6	4.5	8	4.4	8.2	10.3	1.5X1	1720	2745
			300	360			440																				
GPR1202RC3T-370	12	2	100	140	5	80	220	10.5	14	25	45	29	19	10	41	28	35	13	M6	4.5	8	4.4	10.6	12.3	2.7X1	2240	4555
			250	290			370																				
GTR1204EC3T-390	12	4	100	160	5	80	240	9.7	14	30	50	36	26	10	45	32	40	15	M6	4.5	8	4.4	9.8	12.3	2.5X1	3770	6320
			250	310			390																				
GTR1205EC3T-440	12	5	100	160	5	80	240	9.7	14	30	50	40	30	10	45	32	40	15	M6	4.5	8	4.4	9.8	12.3	2.5X1	3770	6320
			300	360			440																				
GTR1210EC3T-460	12	10	100	180	7	80	260	9.9	14	30	50	50	40	10	45	32	40	15	M6	4.5	8	4.4	10	12.5	2.5X1	3820	6480
			300	380			460																				

# 軸端未加工品 UN-WORKED SHAFT ENDS

精度等級 JIS C3級  
Accuracy grede JIS C3  
軸方向すきま 0.005mm以下  
Axial clearance Max. 0.005mm include

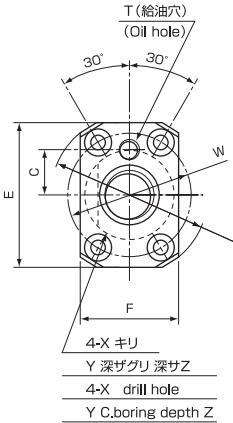
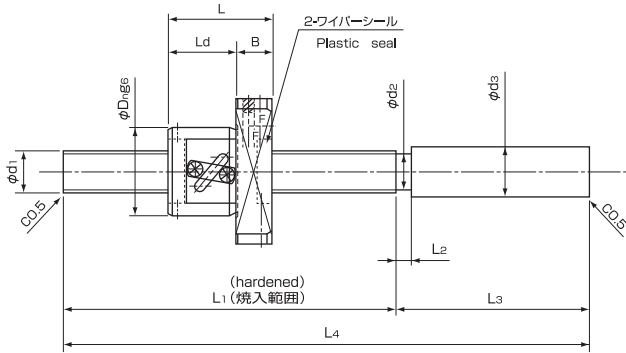

- I 材質 Material  
軸、ナット:SCM415H  
Shaft, Nut:JIS SCM415H
- II 特別仕様品についてはご相談下さい。  
φ4~φ40、長さ1500mm以下  
ステンレス製ボールねじも製作いたします。  
Other specifications are also available.  
Dia.φ4~φ40,Length up to 1500mm Stainless ball screw is also available.
- III 基本定格荷重欄のCaは動定格、Coaは静定格を表わします。尚、この場合の単位はNとなります。  
“Ca” in Basic Load Ratings means Dynamic Load Ratings and “Coa” does Static Load Ratings. Unit in Newton.
- IV ご使用に際しては軸端の追加加工が必要です。軸端の加工は当社にて行うことをお奨めいたします。当社以外で追加加工を行った場合は、追加加工後の精度保証はいたしかねますのでご了承ください。  
Additional machining of screw shaft end is required when ball screw is used. We recommend you to do this machining to ISSOKU, because this machining is performed by other companies except ISSOKU, accuracy for such a ball screw should not be warranted by ISSOKU.

単位:mm unit:mm

呼び番号 Identification number	軸径 Nominal dia.d1	リード Nominal lead	ストローク Stroke	ねじ軸寸法 Screw shaft dimensions									ナット寸法 Nut dimensions											谷径 Root dia.	BCD	回路数 巻×列 Circuits × Turn	基本定格荷重(N) Basic load ratings (N)	
				L1	L2	L3	L4	d2	d3	Dn	A	L	Ld	B	E	F	W	C	T	X	Y	Z	Ca				Coa	
GTR1220AC3T-370 -570 -770	12	20	200	290	10	80	370	9.9	14	30	50	62	50	12	45	32	40	15	M6	4.5	8	4.4	10	12.5	1.5X1	2410	3920	
			400	490			570																					
			600	690			770																					
GPR1402RC3T-330 -480 -630	14	2	200	250	5	80	330	12	15	26	49	30	19	11	44	30	37	14	M6	5.5	9.5	5.4	12.6	14.3	2.7X1	2470	5290	
			350	400			480																					
			500	550			630																					
GTR1405EC3T-360 -510 -660	14	5	200	260	5	100	360	11.1	15	34	57	41	30	11	50	34	45	17	M6	5.5	9.5	5.4	11.2	14.5	2.5X1	6270	11660	
			350	410			510																					
			500	560			660																					
GTR1504EC3T-500 -800 -1200	15	4	300	370	5	130	500	12.6	15	32	56	37	27	10	48	32	43	16	M6	5.5	9.5	5.4	12.8	15.3	2.5X1	4430	7840	
			600	670			800																					
			1000	1070			1200																					
GTR1505EC3T-510 -810 -1210	15	5	300	380	5	130	510	12	15	34	57	41	30	11	50	34	45	17	M6	5.5	9.5	5.4	12.2	15.5	2.5X1	6610	12545	
			600	680			810																					
			1000	1080			1210																					
GTR1510EC3T-520 -820 -1220	15	10	300	390	5	130	520	12	15	34	57	51	40	11	50	34	45	17	M6	5.5	9.5	5.4	12.2	15.5	2.5X1	6610	12545	
			600	690			820																					
			1000	1090			1220																					
GTR1515AC3T-540 -840 -1240	15	15	300	410	5	130	540	12	15	34	57	54	42	12	50	34	45	17	M6	5.5	9.5	5.4	12.4	15.75	1.5X1	4230	7840	
			600	710			840																					
			1000	1110			1240																					
GTR1520AC3T-550 -850 -1250	15	20	300	420	5	130	550	12	15	34	57	62	50	12	50	34	45	17	M6	5.5	9.5	5.4	12.4	15.75	1.5X1	4230	7840	
			600	720			850																					
			1000	1120			1250																					
GPR1602RC3T-380 -530 -680	16	2	200	250	5	130	380	14	16	30	53	30	19	11	48	32	41	16	M6	5.5	9.5	5.4	14.6	16.3	2.7X1	2690	6030	
			350	400			530																					
			500	550			680																					
GTR2005EC3T-630 -1030 -1430	20	5	400	480	5	150	630	17	20	44	67	41	30	11	60	44	55	22	M6	5.5	9.5	5.4	17.2	20.5	2.5X1	8150	17150	
			800	880			1030																					
			1200	1280			1430																					
GTR2010EC3T-650 -1050 -1450	20	10	400	500	10	150	650	16.5	20	46	74	54	41	13	66	46	59	24	M6	6.6	11	6.5	16.8	21	2.5X1	11100	22100	
			800	900			1050																					
			1200	1300			1450																					
GTR2020AC3T-700 -1100 -1500	20	20	400	550	10	150	700	16.5	20	46	74	70	55	15	66	46	59	24	M6	6.6	11	6.5	16.8	21	1.5X1	6710	12640	
			800	950			1100																					
			1200	1350			1500																					

標準軸端未加工品 C5 シリーズ  
Standard un-worked shaft end type Accuracy grade C5

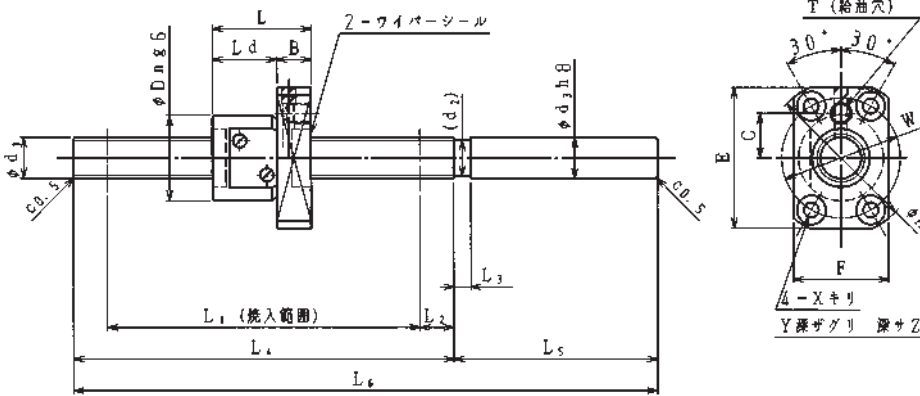

- 注) 1. ご使用に際しては軸端の追加加工が必要です。軸端の加工はISSOKUにて行なう事をお奨めします。ISSOKU以外での追加加工後の精度保証は致しかねますのでご了承下さい。  
2. ナットの稼動に際してはL<sub>1</sub>範囲内のご使用をお願いします。

- Note) 1. The shaft end needs to be re-machined before use, and we recommend the work be performed by ISSOKU. Please be noted that we will not assure the accuracy of the product with a shaft end that is machined by anyone other than ISSOKU.  
2. Keep the nut travel within the range L<sub>1</sub> when the ball screw is used.

ボールねじ諸元

形式	ねじ軸		リード	ボール径	BCD	回路数 巻×列	基本定格荷重 (N)		精度 等級	軸方向ずきま
	外径	谷径					動定格 Ca	静定格 Coa		
GPR0802RC5T	8	6.6	2	1.5875	8.3	2.7×1	1690	3085	C5	0.005 以下
GPR1202RC5T	12	10.6	2	1.5875	12.3	2.7×1	2240	4555		
GPR1602RC5T	16	14.6	2	1.5875	16.3	2.7×1	2690	6030		

ボールねじ形状寸法

呼び番号	ねじ軸寸法										ナット寸法											
	L <sub>1</sub>	L <sub>2</sub>	L <sub>3</sub>	L <sub>4</sub>	L <sub>5</sub>	L <sub>6</sub>	d <sub>1</sub>	d <sub>2</sub>	d <sub>3</sub>	Dn	A	L	Ld	B	E	F	W	C	T	X	Y	Z
GPR0802RC5T -220	123	17	3	160	60	220	8	6.5	10	20	40	25	19	6	36	25	30	—	—	4.5	8	4.4
GPR1202RC5T -220	125	15	5	160	60	220	12	10.5	12	25	45	29	19	10	41	28	35	13	M6	4.5	8	4.4
	205			240		300																
GPR1602RC5T -300	205	15	5	240	60	300	16	14	16	30	53	30	19	11	48	32	41	16	M6	5.5	9.5	5.4
	305			340		400																

標準軸端未加工品 C5 シリーズ  
Standard un-worked shaft end type Accuracy grade C5

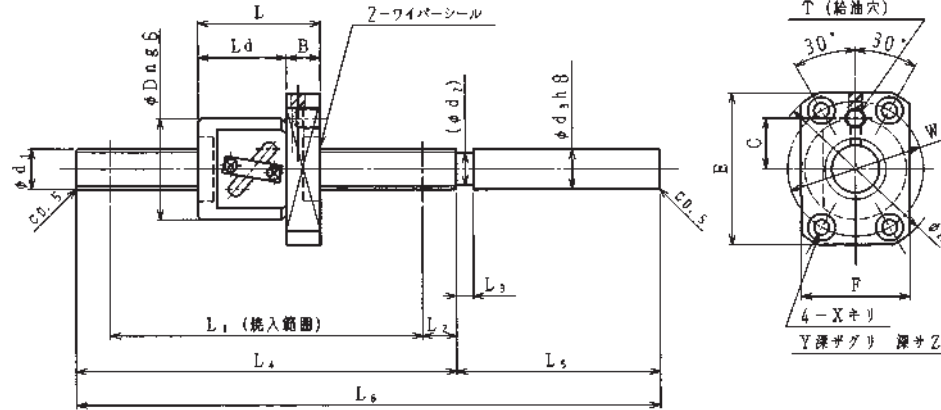

- 注) 1. ご使用に際しては軸端の追加加工が必要です。軸端の加工はISSOKUにて行なう事をお奨めします。ISSOKU以外での追加加工後の精度保証は致しかねますのでご了承下さい。  
2. ナットの稼動に際してはL<sub>1</sub>範囲内のご使用をお願いします。

- Note) 1. The shaft end needs to be re-machined before use, and we recommend the work be performed by ISSOKU. Please be noted that we will not assure the accuracy of the product with a shaft end that is machined by anyone other than ISSOKU.  
2. Keep the nut travel within the range L<sub>1</sub> when the ball screw is used.

ボールねじ諸元

形式	ねじ軸		リード	ボール径	BCD	回路数 巻×列	基本定格荷重 (N)		精度 等級	軸方向ずきま
	外径	谷径					動定格 Ca	静定格 Coa		
GTR0805EC5T	8	6.2	5	2.000	8.3	2.5×1	2290	3575	C5	0.005 以下
GTR0808AC5T			8			1.5×1	1450	2155		
GTR1004EC5T			4			2.5×1	2730	4410		
GTR1010AC5T	10	8.2	10		10.3	1.5×1	1720	2745		

ボールねじ形状寸法

呼び番号	ねじ軸寸法										ナット寸法											
	L <sub>1</sub>	L <sub>2</sub>	L <sub>3</sub>	L <sub>4</sub>	L <sub>5</sub>	L <sub>6</sub>	d <sub>1</sub>	d <sub>2</sub>	d <sub>3</sub>	Dn	A	L	Ld	B	E	F	W	C	T	X	Y	Z
GTR0805EC5T -220	125	15	5	160	60	220	8	6.1	10	24	44	37	29	8	40	27	34	—	—	4.5	8	4.4
GTR0808AC5T -220	128	12	8	160	60	220	8	6.1	10	24	44	36	28	8	40	27	34	—	—	4.5	8	4.4
GTR1004EC5T -280	185	15	5	220	60	280	10	8.1	14	26	46	34	24	10	42	28	36	14	M6	4.5	8	4.4
	285			320		380																
GTR1010AC5T -300	187	13	7	220	80	300	10	8.1	14	26	46	40	30	10	42	28	36	14	M6	4.5	8	4.4
	387			420		500																

### 標準軸端未加工品 C5 シリーズ Standard un-worked shaft end type Accuracy grade C5

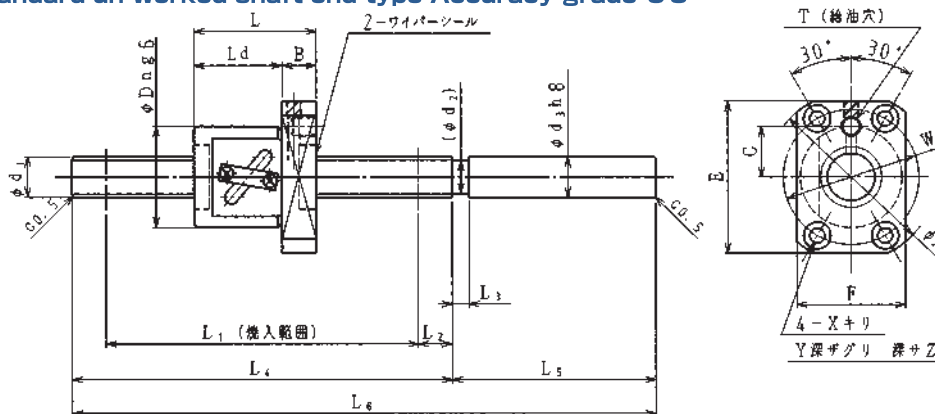

- 注) 1. ご使用に際しては軸端の追加加工が必要です。軸端の加工はISSOKUにて行なう事をお奨めします。ISSOKU以外での追加加工後の精度保証は致しかねますのでご了承下さい。  
2. ナットの稼動に際してはL<sub>1</sub>範囲内のご使用をお願いします。

- Note) 1. The shaft end needs to be re-machined before use, and we recommend the work be performed by ISSOKU. Please be noted that we will not assure the accuracy of the product with a shaft end that is machined by anyone other than ISSOKU.  
2. Keep the nut travel within the range L<sub>1</sub> when the ball screw is used.

#### ボールねじ諸元

形式	ねじ軸		リード	ボール径	BCD	回路数 巻×列	基本定格荷重 (N)		精度 等級	軸方向ずきま
	外径	谷径					動定格 Ca	静定格 Coa		
GTR1205EC5T	12	9.8	5	2.3812	12.3	2.5×1	3770	6320	C5	0.005 以下
GTR1210EC5T		10	10							
GTR1220AC5T		20	20							

#### ボールねじ形状寸法

呼び番号	ねじ軸寸法										ナット寸法												
	L <sub>1</sub>	L <sub>2</sub>	L <sub>3</sub>	L <sub>4</sub>	L <sub>5</sub>	L <sub>6</sub>	d <sub>1</sub>	d <sub>2</sub>	d <sub>3</sub>	Dn	A	L	Ld	B	E	F	W	C	T	X	Y	Z	
GTR1205EC5T	-300	205	15	5	240	60	300	12	10.2	12	30	50	40	30	10	45	32	40	15	M6	4.5	8	4.4
	-450	355			390		450																
GTR1210EC5T	-300	205	15	5	240	60	300	12	10.2	12	30	50	50	40	10	45	32	40	15	M6	4.5	8	4.4
	-450	355			390		450																
GTR1220AC5T	-450	355	15	5	390	60	450	12	10.2	12	30	50	62	50	12	45	32	40	15	M6	4.5	8	4.4
	-600	505			540		600																

### 標準軸端未加工品 C5 シリーズ Standard un-worked shaft end type Accuracy grade C5

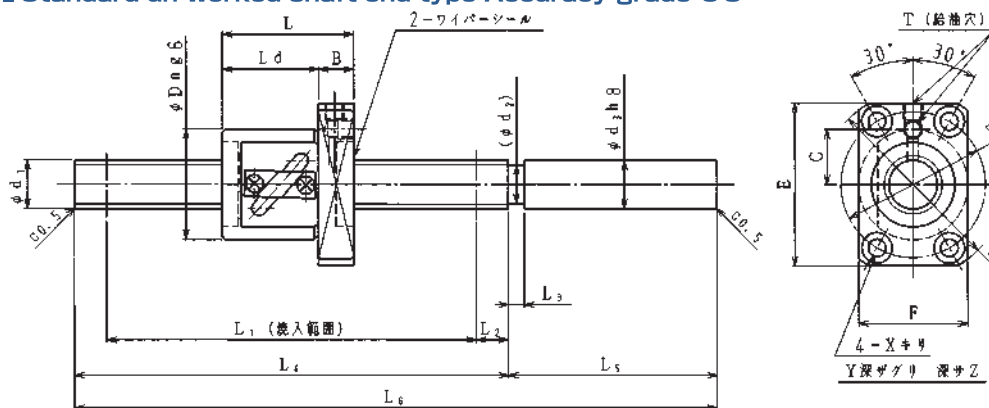

- 注) 1. ご使用に際しては軸端の追加加工が必要です。軸端の加工はISSOKUにて行なう事をお奨めします。ISSOKU以外での追加加工後の精度保証は致しかねますのでご了承下さい。  
2. ナットの稼動に際してはL<sub>1</sub>範囲内のご使用をお願いします。

- Note) 1. The shaft end needs to be re-machined before use, and we recommend the work be performed by ISSOKU. Please be noted that we will not assure the accuracy of the product with a shaft end that is machined by anyone other than ISSOKU.  
2. Keep the nut travel within the range L<sub>1</sub> when the ball screw is used.

#### ボールねじ諸元

形式	ねじ軸		リード	ボール径	BCD	回路数 巻×列	基本定格荷重 (N)		精度 等級	軸方向ずきま
	外径	谷径					動定格 Ca	静定格 Coa		
GTR1505EC5T	15	12.2	5	3.175	15.5	2.5×1	6610	12545	C5	0.005 以下
GTR1510EC5T			10							

#### ボールねじ形状寸法

呼び番号	ねじ軸寸法										ナット寸法												
	L <sub>1</sub>	L <sub>2</sub>	L <sub>3</sub>	L <sub>4</sub>	L <sub>5</sub>	L <sub>6</sub>	d <sub>1</sub>	d <sub>2</sub>	d <sub>3</sub>	Dn	A	L	Ld	B	E	F	W	C	T	X	Y	Z	
GTR1505EC5T	-300	205	15	5	240	60	15	12.2	15	34	57	41	30	11	50	34	45	17	M6	5.5	9.5	5.4	
	-450	355			390																		450
	-600	505			540																		600
	-750	655			690																		750
	-900	805			840																		900
GTR1510EC5T	-300	205	15	5	240	60	15	12.2	15	34	57	51	40	11	50	34	45	17	M6	5.5	9.5	5.4	
	-450	355			390																		450
	-600	505			540																		600
	-750	655			690																		750
	-900	805			840																		900
	-1100	1005			1040																		1100

標準軸端未加工品 C5 シリーズ  
Standard un-worked shaft end type Accuracy grade C5

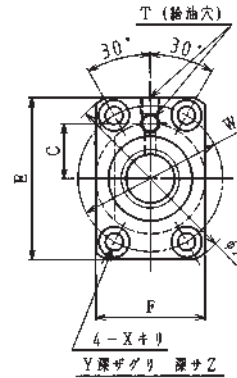
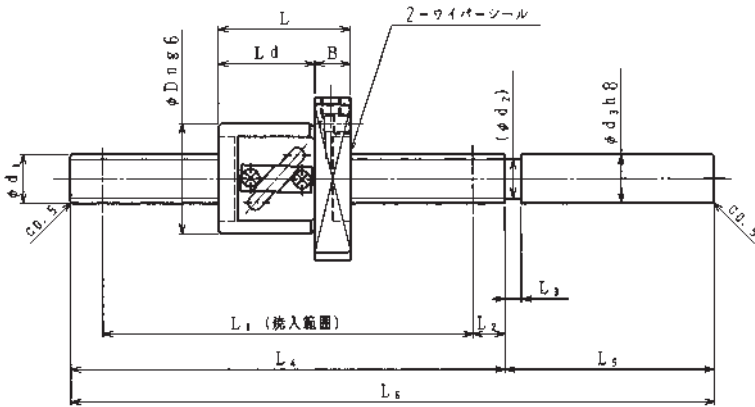

注) 1. ご使用に際しては軸端の追加加工が必要です。軸端の加工はISSOKUにて行なう事をお奨めします。ISSOKU以外での追加加工後の精度保証は致しかねますのでご了承下さい。  
2. ナットの稼動に際してはL<sub>1</sub>範囲内のご使用をお願いします。

Note) 1. The shaft end needs to be re-machined before use, and we recommend the work be performed by ISSOKU. Please be noted that we will not assure the accuracy of the product with a shaft end that is machined by anyone other than ISSOKU.  
2. Keep the nut travel within the range L<sub>1</sub> when the ball screw is used.

ボールねじ諸元

形式	ねじ軸		リード	ボール径	BCD	回路数 巻×列	基本定格荷重 (N)		精度 等級	軸方向ずきま
	外径	谷径					動定格 Ca	静定格 Coa		
GTR1520AC5T	15	12.4	20	3.175	15.75	1.5×1	4230	7840	C5	0.005以下
GTR2005EC5T	20	17.2	5		20.5	2.5×1	8150	17150		

ボールねじ形状寸法

呼び番号	ねじ軸寸法										ナット寸法												
	L <sub>1</sub>	L <sub>2</sub>	L <sub>3</sub>	L <sub>4</sub>	L <sub>5</sub>	L <sub>6</sub>	d <sub>1</sub>	d <sub>2</sub>	d <sub>3</sub>	Dn	A	L	Ld	B	E	F	W	C	T	X	Y	Z	
GTR1520AC5T	-450	355			390		450																
	-600	505			540		600																
	-750	655			690		750																
	-900	805	15	5	840	60	900	15	12.2	15	34	57	62	50	12	50	34	45	17	M6	5.5	9.5	5.4
	-1000	905			940		1000																
	-1100	1005			1040		1100																
GTR2005EC5T	-400	285			320		400																
	-600	485	15	5	520	80	600	20	17.2	20	44	67	41	30	11	60	44	55	22	M6	5.5	9.5	5.4
	-800	685			720		800																
	-1000	885			920		1000																

標準軸端未加工品 C5 シリーズ  
Standard un-worked shaft end type Accuracy grade C5

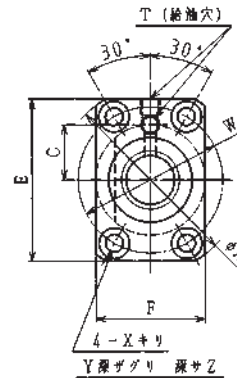
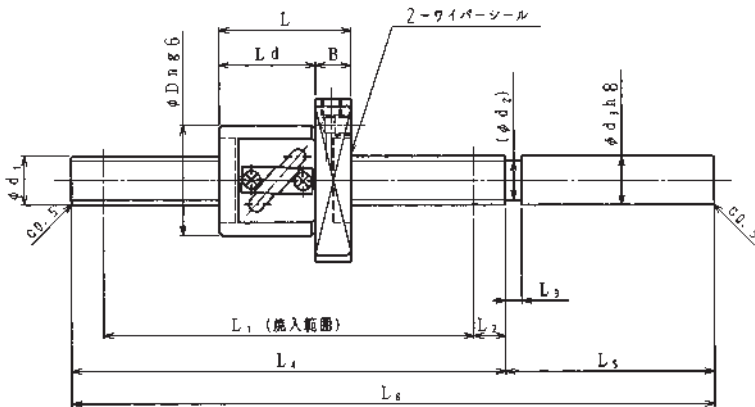

注) 1. ご使用に際しては軸端の追加加工が必要です。軸端の加工はISSOKUにて行なう事をお奨めします。ISSOKU以外での追加加工後の精度保証は致しかねますのでご了承下さい。  
2. ナットの稼動に際してはL<sub>1</sub>範囲内のご使用をお願いします。

Note) 1. The shaft end needs to be re-machined before use, and we recommend the work be performed by ISSOKU. Please be noted that we will not assure the accuracy of the product with a shaft end that is machined by anyone other than ISSOKU.  
2. Keep the nut travel within the range L<sub>1</sub> when the ball screw is used.

ボールねじ諸元

形式	ねじ軸		リード	ボール径	BCD	回路数 巻×列	基本定格荷重 (N)		精度 等級	軸方向ずきま
	外径	谷径					動定格 Ca	静定格 Coa		
GTR2010EC5T	20	16.8	10	3.969	21	2.5×1	11100	22100	C5	0.005以下
GTR2020AC5T			20			1.5×1	6710	12640		

ボールねじ形状寸法

呼び番号	ねじ軸寸法										ナット寸法												
	L <sub>1</sub>	L <sub>2</sub>	L <sub>3</sub>	L <sub>4</sub>	L <sub>5</sub>	L <sub>6</sub>	d <sub>1</sub>	d <sub>2</sub>	d <sub>3</sub>	Dn	A	L	Ld	B	E	F	W	C	T	X	Y	Z	
GTR2010EC5T	-600	485			515		600																
	-800	685			715		800																
	-1000	885	10	10	915	85	1000	20	17.2	20	46	74	54	41	13	66	46	59	24	M6	6.6	11	6.5
	-1300	1185			1215		1300																
	-1500	1385			1415		1500																
GTR2020AC5T	-800	685			715		800																
	-1000	885			915		1000																
	-1300	1185	10	10	1215	85	1300	20	17.2	20	46	74	70	55	15	66	46	59	24	M6	6.6	11	6.5
	-1500	1385			1415		1500																
	-1650	1535			1565		1650																
	-1800	1685			1715		1800																

標準軸端未加工品 C7 シリーズ  
Standard un-worked shaft end type Accuracy grade C7

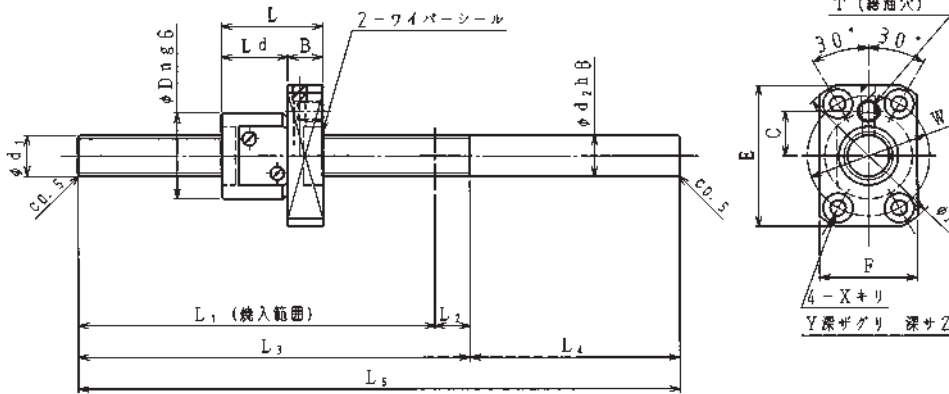

- 注) 1. ご使用に際しては軸端の追加加工が必要です。軸端の加工はISSOKUにて行なう事をお奨めします。ISSOKU以外での追加加工後の精度保証は致しかねますのでご了承下さい。  
2. ナットの稼動に際してはL<sub>1</sub>範囲でのご使用をお願いします。  
3. 軸端未加工部の長さ (L<sub>4</sub>) 変更につきましては別途ご相談下さい。

- Note) 1. The shaft end needs to be re-machined before use, and we recommend the work be performed by ISSOKU. Please be noted that we will not assure the accuracy of the product with a shaft end that is machined by anyone other than ISSOKU.  
2. Keep the nut travel within the range L<sub>1</sub> when the ball screw is used.  
3. Contact us if you need to change the un-worked shaft end length (L<sub>4</sub>).

ボールねじ諸元

単位: mm

形式	ねじ軸		リード	ボール径	BCD	回路数 巻×列	基本定格荷重 (N)		精度 等級	軸方向ずきま
	外径	谷径					動定格 Ca	静定格 Coa		
LPR0802RC7S	8	6.6	2	1.5875	8.3	2.7×1	1690	3085	C7	0.020 以下
LPR1002RC7S	10	8.6			10.3		1980	3820		
LPR1202RC7S	12	10.6			12.3		2240	4555		

ボールねじ形状寸法

単位: mm

呼び番号	ねじ軸寸法										ナット寸法										
	L <sub>1</sub>	L <sub>2</sub>	L <sub>3</sub>	L <sub>4</sub>	L <sub>5</sub>	d <sub>1</sub>	d <sub>2</sub>	Dn	A	L	Ld	B	E	F	W	C	T	X	Y	Z	
LPR0802RC7S	-200	120	20	140	60	200	8	8	20	40	25	19	6	36	25	30	—	—	4.5	8	4.4
	-400	320		340		400															
LPR1002RC7S	-400	320	20	340	60	400	10	10	23	43	29	19	10	39	27	33	12	M6	4.5	8	4.4
	-750	670		690		750															
LPR1202RC7S	-250	170	20	190	60	250	12	12	25	45	29	19	10	41	28	35	13	M6	4.5	8	4.4
	-500	420		440		500															
-750	670	690	750																		

標準軸端未加工品 C7 シリーズ  
Standard un-worked shaft end type Accuracy grade C7

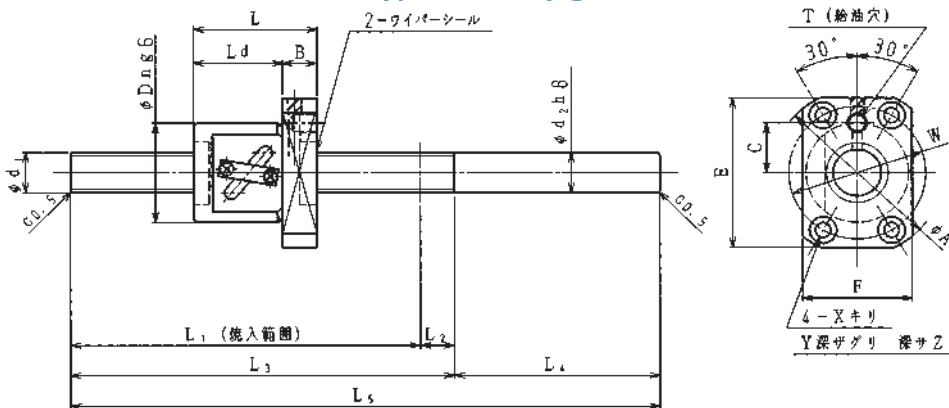

- 注) 1. ご使用に際しては軸端の追加加工が必要です。軸端の加工はISSOKUにて行なう事をお奨めします。ISSOKU以外での追加加工後の精度保証は致しかねますのでご了承下さい。  
2. ナットの稼動に際してはL<sub>1</sub>範囲でのご使用をお願いします。  
3. 軸端未加工部の長さ (L<sub>4</sub>) 変更につきましては別途ご相談下さい。

- Note) 1. The shaft end needs to be re-machined before use, and we recommend the work be performed by ISSOKU. Please be noted that we will not assure the accuracy of the product with a shaft end that is machined by anyone other than ISSOKU.  
2. Keep the nut travel within the range L<sub>1</sub> when the ball screw is used.  
3. Contact us if you need to change the un-worked shaft end length (L<sub>4</sub>).

ボールねじ諸元

単位: mm

形式	ねじ軸		リード	ボール径	BCD	回路数 巻×列	基本定格荷重 (N)		精度 等級	軸方向ずきま
	外径	谷径					動定格 Ca	静定格 Coa		
LTR0804EC7S	8	6.2	4	2.000	8.3	2.5×1	2420	3620	C7	0.020 以下
LTR0808AC7S			8							
LTR1005EC7S	5									
LTR1010AC7S	10	8.2	10	10.3	2.5×1	2730	4410			
					1.5×1	1720	2745			

ボールねじ形状寸法

単位: mm

呼び番号	ねじ軸寸法										ナット寸法										
	L <sub>1</sub>	L <sub>2</sub>	L <sub>3</sub>	L <sub>4</sub>	L <sub>5</sub>	d <sub>1</sub>	d <sub>2</sub>	Dn	A	L	Ld	B	E	F	W	C	T	X	Y	Z	
LTR0804EC7S	-200	120	20	140	60	200	8	8	24	44	33	25	8	40	27	34	—	—	4.5	8	4.4
	-400	320		340		400															
LTR0808AC7S	-200	120	20	140	60	200	8	8	24	44	36	28	8	40	27	34	—	—	4.5	8	4.4
	-400	320		340		400															
LTR1005EC7S	-420	340	20	360	60	420	10	10	26	46	40	30	10	42	28	36	14	M6	4.5	8	4.4
	-780	700		720		780															
LTR1010AC7S	-420	320	20	340	80	420	10	10	26	46	40	30	10	42	28	36	14	M6	4.5	8	4.4
	-780	680		700		780															

標準軸端未加工品 C7 シリーズ  
Standard un-worked shaft end type Accuracy grade C7

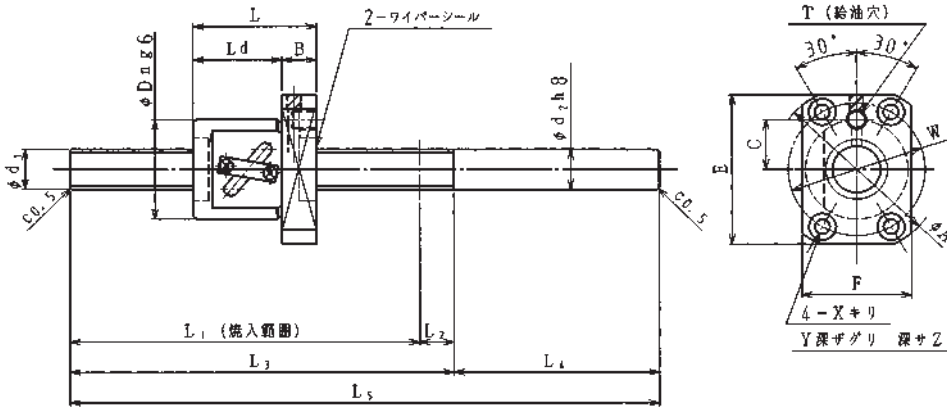

- 注) 1. ご使用に際しては軸端の追加加工が必要です。軸端の加工はISSOKUにて行なう事をお奨めします。ISSOKU以外での追加加工後の精度保証は致しかねますのでご了承下さい。  
2. ナットの稼動に際してはL1範囲内での使用をお願いします。  
3. 軸端未加工部の長さ (L4) 変更につきましては別途ご相談下さい。

- Note) 1. The shaft end needs to be re-machined before use, and we recommend the work be performed by ISSOKU. Please be noted that we will not assure the accuracy of the product with a shaft end that is machined by anyone other than ISSOKU.  
2. Keep the nut travel within the range L<sub>1</sub> when the ball screw is used.  
3. Contact us if you need to change the un-worked shaft end length (L<sub>4</sub>).

ボールねじ諸元

単位: mm

形式	ねじ軸		リード	ボール径	BCD	回路数 巻×列	基本定格荷重 (N)		精度 等級	軸方向ずきま
	外径	谷径					動定格 Ca	静定格 Coa		
LTR1205EC7S	12	9.8	5	2.3812	12.3	2.5×1	3770	6320	C7	0.020 以下
LTR1210EC7S		10.0	10		12.5		3820	6480		
LTR1220AC7S		20	20		12.5		2410	3920		

ボールねじ形状寸法

単位: mm

呼び番号	ねじ軸寸法								ナット寸法												
	L <sub>1</sub>	L <sub>2</sub>	L <sub>3</sub>	L <sub>4</sub>	L <sub>5</sub>	d <sub>1</sub>	d <sub>2</sub>	Dn	A	L	Ld	B	E	F	W	C	T	X	Y	Z	
LTR1205EC7S	-250	170	190	250	12	12	30	50	40	30	10	45	32	40	15	M6	4.5	8	4.4		
	-500	420	20	440	60	500	12	12	30	50	50	40	10	45	32	40	15	M6	4.5	8	4.4
	-750	670	690	750	12	12	30	50	50	40	10	45	32	40	15	M6	4.5	8	4.4		
LTR1210EC7S	-250	170	190	250	12	12	30	50	40	30	10	45	32	40	15	M6	4.5	8	4.4		
	-500	420	20	440	60	500	12	12	30	50	50	40	10	45	32	40	15	M6	4.5	8	4.4
	-750	670	690	750	12	12	30	50	50	40	10	45	32	40	15	M6	4.5	8	4.4		
LTR1220AC7S	-500	920	940	1000	12	12	30	50	62	50	12	45	32	40	15	M6	4.5	8	4.4		
	-750	420	20	440	60	500	12	12	30	50	62	50	12	45	32	40	15	M6	4.5	8	4.4
	-1000	670	690	750	12	12	30	50	62	50	12	45	32	40	15	M6	4.5	8	4.4		

標準軸端未加工品 C7 シリーズ  
Standard un-worked shaft end type Accuracy grade C7

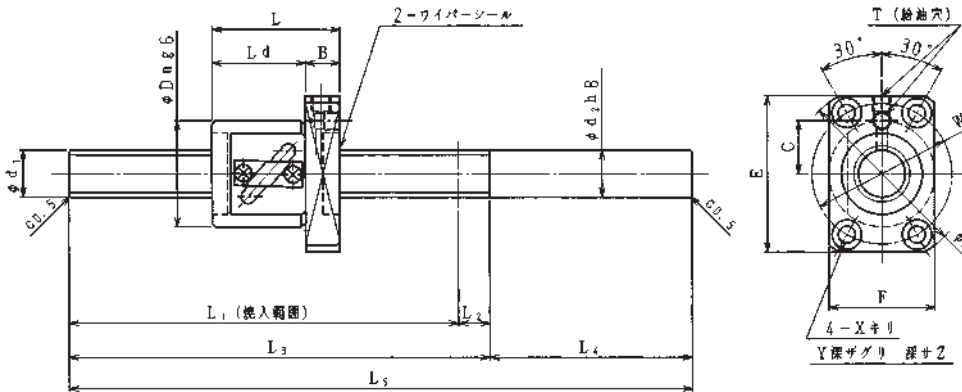

- 注) 1. ご使用に際しては軸端の追加加工が必要です。軸端の加工はISSOKUにて行なう事をお奨めします。ISSOKU以外での追加加工後の精度保証は致しかねますのでご了承下さい。  
2. ナットの稼動に際してはL1範囲内での使用をお願いします。  
3. 軸端未加工部の長さ (L4) 変更につきましては別途ご相談下さい。

- Note) 1. The shaft end needs to be re-machined before use, and we recommend the work be performed by ISSOKU. Please be noted that we will not assure the accuracy of the product with a shaft end that is machined by anyone other than ISSOKU.  
2. Keep the nut travel within the range L<sub>1</sub> when the ball screw is used.  
3. Contact us if you need to change the un-worked shaft end length (L<sub>4</sub>).

ボールねじ諸元

単位: mm

形式	ねじ軸		リード	ボール径	BCD	回路数 巻×列	基本定格荷重 (N)		精度 等級	軸方向ずきま
	外径	谷径					動定格 Ca	静定格 Coa		
LTR1505EC7S	15	12.2	5	3.175	15.5	2.5×1	6610	12545	C7	0.020 以下
LTR1510EC7S		12.4	10		15.5		6610	12545		
LTR1520AC7S		20	20		15.75		1.5×1	4230		

ボールねじ形状寸法

単位: mm

呼び番号	ねじ軸寸法								ナット寸法												
	L <sub>1</sub>	L <sub>2</sub>	L <sub>3</sub>	L <sub>4</sub>	L <sub>5</sub>	d <sub>1</sub>	d <sub>2</sub>	Dn	A	L	Ld	B	E	F	W	C	T	X	Y	Z	
LTR1505EC7S	-500	420	20	440	60	500	15	15	34	57	41	30	11	50	34	45	17	M6	5.5	9.5	5.4
	-1000	920	20	940	60	1000	15	15	34	57	51	40	11	50	34	45	17	M6	5.5	9.5	5.4
	-1500	1420	1440	1500	15	15	34	57	51	40	11	50	34	45	17	M6	5.5	9.5	5.4		
LTR1510EC7S	-500	420	20	440	60	500	15	15	34	57	41	30	11	50	34	45	17	M6	5.5	9.5	5.4
	-1000	920	20	940	60	1000	15	15	34	57	51	40	11	50	34	45	17	M6	5.5	9.5	5.4
	-1500	1420	1440	1500	15	15	34	57	51	40	11	50	34	45	17	M6	5.5	9.5	5.4		
LTR1520AC7S	-500	420	20	440	60	500	15	15	34	57	62	50	12	50	34	45	17	M6	5.5	9.5	5.4
	-1000	920	20	940	60	1000	15	15	34	57	62	50	12	50	34	45	17	M6	5.5	9.5	5.4
	-1500	1420	1440	1500	15	15	34	57	62	50	12	50	34	45	17	M6	5.5	9.5	5.4		

標準軸端未加工品 C7 シリーズ  
Standard un-worked shaft end type Accuracy grade C7

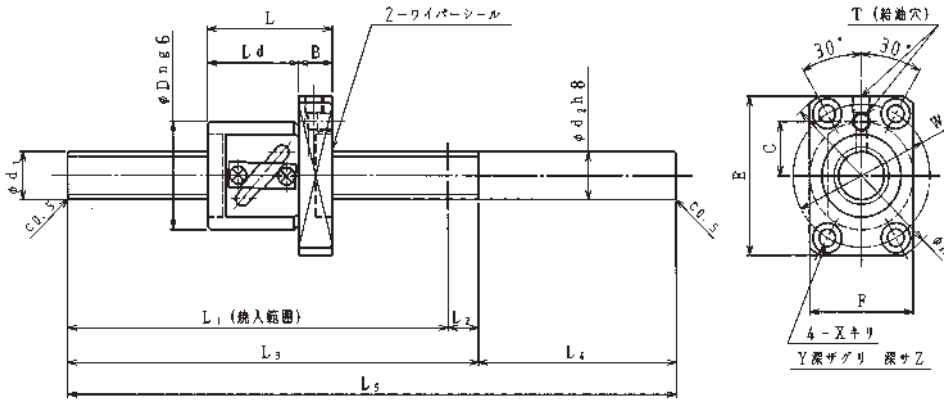

- 注) 1. ご使用に際しては軸端の追加加工が必要です。軸端の加工はISSOKUにて行なう事をお奨めします。ISSOKU以外での追加加工後の精度保証は致しかねますのでご了承下さい。  
2. ナットの稼動に際してはL1範囲でのご使用をお願いします。  
3. 軸端未加工部の長さ (L4) 変更につきましては別途ご相談下さい。

Note) 1. The shaft end needs to be re-machined before use, and we recommend the work be performed by ISSOKU. Please be noted that we will not assure the accuracy of the product with a shaft end that is machined by anyone other than ISSOKU.

2. Keep the nut travel within the range L<sub>1</sub> when the ball screw is used.

3. Contact us if you need to change the un-worked shaft end length (L<sub>4</sub>).

ボールねじ諸元

単位: mm

形式	ねじ軸		リード	ボール径	BCD	回路数 巻×列	基本定格荷重 (N)		精度 等級	軸方向すきま
	外径	谷径					動定格 Ca	静定格 Coa		
LTR2005EC7S	20	17.2	5	3.175	20.5	2.5×1	8150	17150	C7	0.020 以下
LTR2010EC7S		16.8	10	3.969	21		11100	22100		
LTR2020AC7S		20	20				6710	12640		

ボールねじ形状寸法

単位: mm

呼び番号	ねじ軸寸法								ナット寸法											
	L <sub>1</sub>	L <sub>2</sub>	L <sub>3</sub>	L <sub>4</sub>	L <sub>5</sub>	d <sub>1</sub>	d <sub>2</sub>	Dn	A	L	Ld	B	E	F	W	C	T	X	Y	Z
LTR2005EC7S	-500	400	20	420	500	20	20	44	67	41	30	11	60	44	55	22	M6	5.5	9.5	5.4
	-1000	900	920	1000																
	-1500	1400	1420	1500																
LTR2010EC7S	-500	395	20	415	500	20	20	46	74	54	41	13	66	46	59	24	M6	6.6	11	6.5
	-1000	895	915	1000																
	-1500	1395	1415	1500																
	-2000	1895	1915	2000																
LTR2020AC7S	-500	395	20	415	500	20	20	46	74	70	55	15	66	46	59	24	M6	6.6	11	6.5
	-1000	895	915	1000																
	-1500	1395	1415	1500																
	-2000	1895	1915	2000																

標準軸端未加工品 C7 シリーズ  
Standard un-worked shaft end type Accuracy grade C7

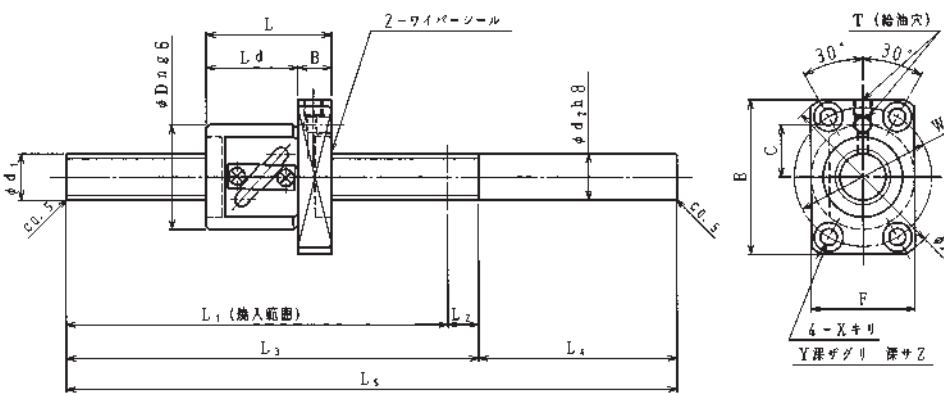

- 注) 1. ご使用に際しては軸端の追加加工が必要です。軸端の加工はISSOKUにて行なう事をお奨めします。ISSOKU以外での追加加工後の精度保証は致しかねますのでご了承下さい。  
2. ナットの稼動に際してはL1範囲でのご使用をお願いします。  
3. 軸端未加工部の長さ (L4) 変更につきましては別途ご相談下さい。

Note) 1. The shaft end needs to be re-machined before use, and we recommend the work be performed by ISSOKU. Please be noted that we will not assure the accuracy of the product with a shaft end that is machined by anyone other than ISSOKU.

2. Keep the nut travel within the range L<sub>1</sub> when the ball screw is used.

3. Contact us if you need to change the un-worked shaft end length (L<sub>4</sub>).

ボールねじ諸元

単位: mm

形式	ねじ軸		リード	ボール径	BCD	回路数 巻×列	基本定格荷重 (N)		精度 等級	軸方向すきま
	外径	谷径					動定格 Ca	静定格 Coa		
LTR2505EC7S	25	22.2	5	3.175	25.5	2.5×1	7970	19340	C7	0.020 以下
LTR2510EC7S		20.5	10	4.7625	26		13120	27000		
LTR2520AC7S		21.3	20				8540	16900		

ボールねじ形状寸法

単位: mm

呼び番号	ねじ軸寸法								ナット寸法											
	L <sub>1</sub>	L <sub>2</sub>	L <sub>3</sub>	L <sub>4</sub>	L <sub>5</sub>	d <sub>1</sub>	d <sub>2</sub>	Dn	A	L	Ld	B	E	F	W	C	T	X	Y	Z
LTR2505EC7S	-500	315	20	335	500	25	25	50	73	40	29	11	66	50	61	25	M6	5.5	9.5	5.4
	-1000	815	835	1000																
	-1500	1315	1165	1500																
	-2000	1815	1835	2000																
LTR2510EC7S	-500	310	20	330	500	25	25	58	92	67	52	15	82	58	74	30	M6	9	14	9
	-1000	810	830	1000																
	-1500	1310	1330	1500																
	-2000	1810	1830	2000																
LTR2520AC7S	-500	310	20	330	500	25	25	58	92	75	57	18	82	58	74	30	M6	9	14	9
	-1000	810	830	1000																
	-1500	1310	1330	1500																
	-2000	1810	1830	2000																



# 軸端未加工品 ステンレスシリーズ UN-WORKED SHAFT ENDS SUS

精度等級 JIS C3級  
Accuracy grade JIS C3

軸方向すきま 0.005mm以下  
Axial clearance Max.0.005mm include

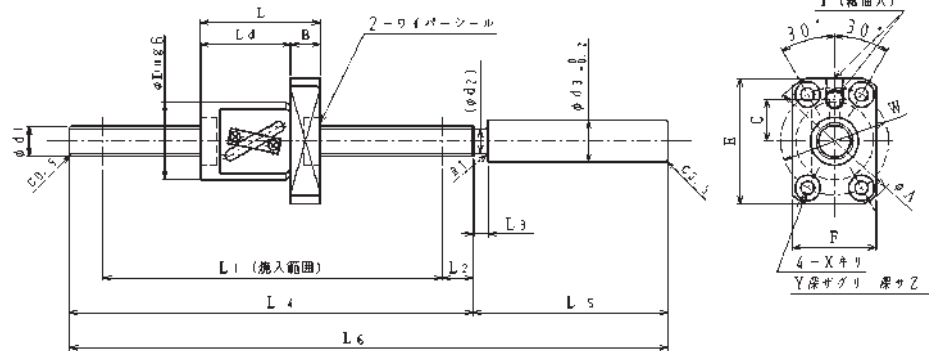

- I 材質 Material  
軸、ナット:SUS440C  
Shaft, Nut: JIS SUS440C
- II 特別仕様品についてはご相談ください。  
φ4~φ40、長さ1500mm以下  
Other specifications are also available. Dia.φ4~φ40, Length up to 1500mm
- III ご使用に際しては軸端の追加加工が必要です。  
軸端の加工は当社にて行うことをお奨めいたします。  
当社以外で追加加工を行った場合は、追加加工後の精度保証は致しかねますのでご了承ください。  
Additional machining of screw shaft end is required when ballscrew is used.  
We recommend you to do this machining to Issoku, because this machining is performed by other companies expect ISSOKU, accuracy for such a ball screw not be warranted by ISSOKU.
- IV ご使用前に必ず潤滑剤を供給して下さい。  
また、クリーン用及び真空用には洗浄・脱脂後に用途に応じた潤滑剤を供給してください。  
Surely supply the lubricant before use. When this screw is used in clean air or in vacuum, also supply the lubricant which is applied to the condition used after wash or removing oil.

単位:mm Unit:mm

呼び番号 Identification number	軸径 Nominal dia. d1	リード Nominal lead	ねじ軸寸法 Screw shaft dimensions									ナット寸法 Nut dimensions											谷径 Roo dia.	BCD	回路数 巻×列 Circuits X Turn	基本定格荷重(N) Basic load ratings(N)		
			L1	L2	L3	L4	L5	L6	d2	d3	Dn	A	L	Ld	B	E	F	W	C	T	X	Y				Z	Ca	C0a
GPR0401RC3T -100 SUS (注) (Noce)	4	1	24	16	4	60	40	100	4	10	11	21	19	15	4	-	14	16	-	-	2.9	-	-	3.3	4.15	2.7X1	380	550
-140 SUS GPR0601RC3T -190 SUS	6	1	53 103	17	3	90 140	50	140 190	5.2	10	13	29	20	15	5	26	19	21	-	-	3.4	6.5	3	5.3	6.15	2.7X1	500	790
-150 SUS GPR0602RC3T -200 SUS	6	2	63 113	17	3	100 150	50	150 200	4.5	10	18	34	24	19	5	31	22	26	-	-	3.4	6.5	3	4.6	6.3	2.7X1	1080	1650
-150 SUS GPR0801RC3T -220 SUS	8	1	53 123	17	3	90 160	60	150 220	7.2	10	16	32	20	15	5	29	21	24	-	-	3.4	6.5	3	7.3	8.15	2.7X1	600	1060
-160 SUS GPR0802RC3T -230 SUS	8	2	63 133	17	3	100 170	60	160 230	6.5	10	20	40	25	19	6	36	25	30	-	-	4.5	8	4.4	6.6	8.3	2.7X1	1350	2160
-180 SUS GTR0805EC3T -240 SUS	8	5	85 145	15	5	120 180	60	180 240	6.1	10	24	44	37	29	8	40	27	34	-	-	4.5	8	4.4	6.2	8.3	2.5X1	1830	2500
-220 SUS GPR1002RC3T -320 SUS	10	2	105 205	15	5	140 240	80	220 320	8.5	14	23	43	29	19	10	39	27	33	12	M6	4.5	8	4.4	8.6	10.3	2.7X1	1580	2670
-230 SUS GTR1004EC3T -380 SUS	10	4	115 265	15	5	150 300	80	230 380	8.1	14	26	46	34	24	10	42	28	36	14	M6	4.5	8	4.4	8.2	10.3	2.5X1	2180	3090
-240 SUS GTR1005EC3T -390 SUS	10	5	125 275	15	5	160 310	80	240 390	8.1	14	26	46	40	30	10	42	28	36	14	M6	4.5	8	4.4	8.2	10.3	2.5X1	2180	3090
-220 SUS GPR1202RC3T -370 SUS	12	2	105 255	15	5	140 290	80	220 370	10.5	14	25	45	29	19	10	41	28	35	13	M6	4.5	8	4.4	10.6	12.3	2.7X1	1790	3190
-240 SUS GTR1205EC3T -440 SUS	12	5	125 325	15	5	160 360	80	240 440	9.7	14	30	50	40	30	10	45	32	40	15	M6	4.5	8	4.4	9.8	12.3	2.5X1	3020	4420



# 軸端未加工品 ステンレスシリーズ UN-WORKED SHAFT ENDS SUS

精度等級 JIS C3級  
Accuracy grade JIS C3

軸方向すきま 0.005mm以下  
Axial clearance Max.0.005mm include

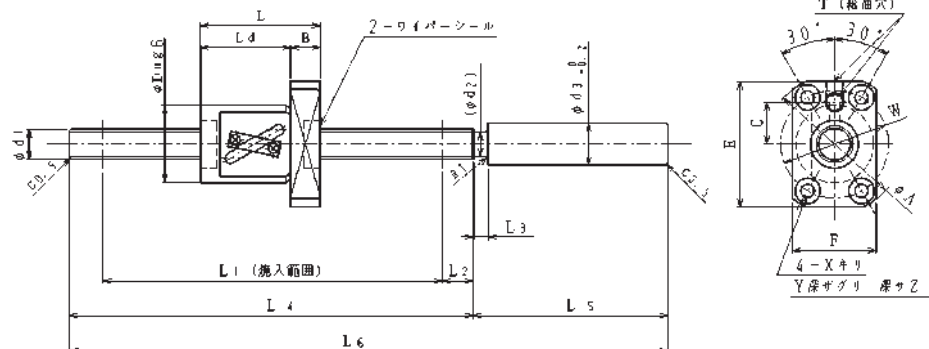

- I 材質 Material  
軸、ナット:SUS440C  
Shaft, Nut:JIS SUS440C
- II 特別仕様品についてはご相談ください。  
φ4~φ40、長さ1500mm以下  
Other specifications are also available. Dia.φ4~φ40,Length up to 1500mm
- III ご使用に際しては軸端の追加加工が必要です。  
軸端の加工は当社にて行うことをお奨めいたします。  
当社以外で追加加工を行った場合は、追加加工後の精度保証は致しかねますのでご了承ください。  
Additional machining of screw shaft end is required when ballscrew is used.  
We recommend you to do this machining to Issoku,because this machiningis performed by other companies expect ISSOKU,accracy for such a ball screw not be warranted by ISSOKU.
- IV ご使用前に必ず潤滑剤を供給して下さい。  
また、クリーン用及び真空用には洗浄・脱脂後に用途に応じた潤滑剤を供給してください。  
Surely supply the lubricant before use.When this screw is used in clean air or in vacuum,also supply the lubricant which is applied to the condition used after wash or removing oil.

単位:mm Unit:mm

呼び番号 Identification number	軸径 Nominal dia.d1	リード Nominal lead	ねじ軸寸法 Screw shaft dimensions										ナット寸法 Nut dimensions										谷径 Roo dia.	BCD	回路数 巻×列 Circuits XTurn	基本定格荷重(N) Basic load ratings(N)		
			L1	L2	L3	L4	L5	L6	d2	d3	Dn	A	L	Ld	B	E	F	W	C	T	X	Y				Z	Ca	C0a
			GTR1210EC3T -260 SUS -460 SUS	12	10	147 347	13	7	180 380	80	260 460	9.9	14	30	50	50	40	10	45	32	40	15				M6	4.5	8
GPR1402RC3T -330 SUS -480 SUS	14	2	215 365	15	5	250 400	80	330 480	12	15	26	49	30	19	11	44	30	37	14	M6	5.5	9.5	5.4	12.6	14.3	2.7X1	1980	3700
GTR1405EC3T -360 SUS -510 SUS	14	5	225 375	15	5	260 410	100	360 510	11.1	15	34	57	41	30	11	50	34	45	17	M6	5.5	9.5	5.4	11.2	14.5	2.5X1	5020	8160
GTR1505EC3T -510 SUS -810 SUS	15	5	345 645	15	5	380 680	130	510 810	12	15	34	57	41	30	11	50	34	45	17	M6	5.5	9.5	5.4	12.2	15.5	2.5X1	5290	8780
GTR1510EC3T -520 SUS -820 SUS	15	10	355 655	15	5	390 690	130	520 820	12	15	34	57	51	40	11	50	34	45	17	M6	5.5	9.5	5.4	12.2	15.5	2.5X1	5290	8780
GTR1520AC3T -550 SUS -850 SUS	15	20	385 685	15	5	420 720	130	550 850	12	15	34	57	62	50	12	50	34	45	17	M6	5.5	9.5	5.4	12.4	15.75	1.5X1	3380	5490
GPR1602RC3T -380 SUS -530 SUS	16	2	215 365	15	5	250 400	130	380 530	14	16	30	53	30	19	11	48	32	41	16	M6	5.5	9.5	5.4	14.6	16.3	2.7X1	2150	4220
GTR2005EC3T -630 SUS -1030 SUS	20	5	445 845	15	5	480 880	150	630 1030	17	20	44	67	41	30	11	60	44	55	22	M6	5.5	9.5	5.4	17.2	20.5	2.5X1	6520	12000
GTR2010EC3T -650 SUS -1050 SUS	20	10	470 870	10	10	500 900	150	650 1050	17	20	46	74	54	41	13	66	46	59	24	M6	6.6	11	6.5	16.8	21	2.5X1	8880	15470
GTR2020AC3T -700 SUS -1100SUS	20	20	520 920	10	10	550 950	150	700 1100	16.5	20	46	74	70	55	15	66	46	59	24	M6	6.6	11	6.5	16.8	21	1.5X1	5370	8850

安全上のご注意 [Safety precautions]

お使いになる人や他の人への危害、財産への損害を未然に防止するため、またボールねじの機能を十分発揮させるため、設計及び取り扱いにあたっては下記の点に十分注意し、ご使用下さい。

設計

- △ 1. ねじ軸の軸端を設計するときは、軸端の片側をねじ軸谷径寸法以下にし、ねじを切り通しにして下さい。
- △ 2. 取付まわりの設計をするときは、ボールねじのナットを抜かなくても取付が可能な構造にして下さい。
- △ 3. ボールねじを装置に垂直に取り付ける場合、安全のための落下防止装置を装置あるいはボールねじに取り付けて下さい。
- △ 4. ボールねじの、異物混入による異常摩耗、ボール循環部の損傷、作動不能状態の発生を防ぐために、異物混入が予想される環境での使用に際しては、防塵カバー等の対策を講じて下さい。
- ⊗ 5. 安全のため、ボールねじの許容荷重、許容回転数を守って装置設計を行って下さい。
- 6. 特殊な温度環境で使用する場合は熱変形による精度変化、潤滑剤の選定、ボールねじの耐熱温度(通常80℃)など考慮に入れて設計して下さい。

追加工

- △ 1. 追加工は、分解による精度低下や切り粉の進入によって寿命低下をもたらす恐れがあります。予めご指定下さい。

潤滑

- △ 1. ご使用前に潤滑剤の状況を確認して下さい。潤滑不良の場合、短期にボールねじの機能を喪失する原因となります。
  - △ 2. 潤滑グリースが塗布されている場合は、そのままご使用下さい。但し、取り扱い上グリース表面にゴミ、切り粉等異物が付着した場合は、清浄な白灯油(水分には十分注意する)で洗浄し、塗布されていた潤滑グリースと同じ新品を再塗布の上ご使用下さい。
  - △ 3. 潤滑剤グリースの点検は、稼働後1~2ヶ月とし、汚れが著しい場合は古いグリースを抜き取り、新しいグリースを十分に塗布して下さい。その後点検、補給の目安は、通常0.5~1年毎又は1,000~2,000時間としますが、使用環境により変わりますので適宜その間隔を認定して下さい。
- オイル潤滑の場合は、油切れにならないように注意して下さい。
- 取り扱い・組み立て

- ⊗ 1. 分解・組立は絶対に行わないで下さい。ボールの脱落や予圧量の変化、異物の進入の恐れがあり、精度、寿命の低下、事故の発生の原因となります。分解・組立の必要がある場合は、有料にてお引き受け致します。
- △ 2. ボールねじは、軸又はナットが自重で分解落下することがありますので、けがに充分注意して下さい。また、誤って落下させてしまった場合は、再組立と精度点検をメーカーにて行う必要があります(有料)。
- ⊗ 3. ボールねじを誤って落下させたり、衝撃を与えたり、オーバランさせたりするとボール脱落や循環部品、ねじ軸外径、ねじ溝面、ボールなどに損傷を与え、回転状態、精度、寿命を維持できなくなると共に、場合によっては事故が生じます。その場合は、メーカー点検(有料)を受けて下さい。
- △ 4. 組み付けに際しては、ボールねじを支持する軸受け部とナットを取り付けるブラケットの芯ずれ、ナット取付面の傾きなど取付部の精度に充分注意して下さい。これらは、ボールねじに偏荷重(ラジアル荷重、モーメント荷重)を与え、作動不良や寿命の低下、発熱、駆動トルクの増大など悪影響をもたらします。
- ⊗ 5. ハウジングへの無理な組み付けはナットの変形を生じさせ、精度、寿命の維持ができなくなります。適正な隙間を設けて下さい。

管理

- △ 1. 保管する場合は、購入時の状態で保管して下さい。無用に梱包を開いたり、内部梱包を破いたりしないようにして下さい。ゴミの進入、発錆の原因となり、機能低下を引き起こす事があります。
- △ 2. 長期保管の場合は、塵埃の付着程度、発錆状態を確認して下さい。
  - ① 購入時の梱包のまま水平において保管する。
  - ② 清浄な場所に、枕木を当て水平において保管する。
  - ③ 清浄な場所に、脱落、落下などしないように処置した後、垂直に吊して保管する。

In order to prevent injury to users or other persons and damage to property and to enable ball screws to display their functions fully, pay careful attention to the following points concerning design and handling.

Design

- 1. When designing the screw shaft ends, make one side of shaft ends smaller than the dimension of minor diameter of screw shaft so that the screw thread cuts through.
- 2. When designing the area around the screw attachment, arrange the structure so that the screw can be attached removing the nut.
- 3. If a ball screw is attached to equipment vertically, attach a dropping-prevention device either to the equipment itself or to the ball screw for safety.
- 4. Intrusion of foreign matter can cause abnormal wear to the ball screw, damage to the ball circulating path, or a situation in which operation is impossible. To prevent these occurrences, provide some sort of dust cover when using ball screws in an environment which is liable to be dusty.
- 5. For safety reasons, make sure the design observes the permissible load and the permissible number of rotations.
- 6. When using ball screws in an extreme temperature environment, make sure the design takes into account the loss of accuracy caused by high temperature, choice of lubricant, heat resistance temperature of the ball screw (normally 80 °C) etc.

Additional machining

- 1. Additional machining may cause a loss of accuracy due to disassembling, or the shortening of service life of ball screw due to intrusion of foreign matter. Specify beforehand.

Lubrication

- 1. Check the condition of the lubricant before use. If lubrication is insufficient, the functions of ball screw will be impaired within a short period of time.
- 2. If lubricating grease has been applied, the screw can be used as it is. However, if foreign matter become attached to the grease surface in the course of handling, wash the screw with pure kerosene (Be careful with water.) and apply a fresh coat of new grease, using the same type of grease as that used originally.
- 3. Check the lubricating grease between one and two months after initial operation and if it is found to be dirty, wipe off the old grease and apply a sufficient coating of new grease. Thereafter, check and replenishments should normally by carried out every 6 to 12 months or after 1000-2000 hours of use. However, this varies according to the environment in which ball screws are used, so establish the intervals of check as appropriate. In case of oil lubrication, make sure oil does not run out.

Handling and assembly

- 1. Do not attempt to disassemble a ball screw. The ball may fall, the preload may change, or foreign matter may enter, causing a loss of accuracy, shortening the life of the ball screw, and giving rise to accidents. If you need to disassemble a ball screw, we will do this work for you (for a fee).
- 2. The shaft and/or nut of a ball screw may become separated and fall due to their own weight, so take care to avoid injuries. If you allow them to fall by mistake, it is essential to ask the manufacturer to reassemble the screw and inspect its accuracy, (for a fee).
- 3. If you drop a ball screw accidentally, subject it to a hard impact, or allow it to overrun, this may cause the ball to fall and/or damage the rotating parts, the screw shaft external diameter, the screw groove surface, the ball, etc., as well as affecting rotation, precision, and the life. In some instances, accidents may occur. Please ask the manufacturer to inspect the screw (for a fee).
- 4. When mounting a ball screw, pay careful attention to the accuracy of the attachment sections. Make sure the shaft holders supporting the ball screw and the bracket attaching the nut are aligned and check the run out of the nut attachment surface. The misalignment cause unbalanced load (radial load, moment load) on the ball screw, resulting in faulty operation, shorter life, heat generation, and an increase in the drive torque.
- 5. Forcing the screw into the housing may cause distortion of the nut which means the accuracy cannot be maintained and the life of the screw is shortened. Make sure there is a suitable clearance.

1. Storing

- 1. Store screws in the same state as when purchased. Do not open the packing unnecessarily or tear the internal wrapping. This can cause dirt to enter or produce rust resulting in poorer functioning.
- 2. When storing for a long time, take suitable precautions to prevent dust and rust and store in the positions described below. Make periodic inspections to check the dust and rust situation.
  - 1. Store horizontally in the packing provided at the time of purchase.
  - 2. Store horizontally in a clean place against a cross tie.
  - 3. Store by hanging vertically in a clean place making sure there is no falling down.

# 丸形サポートユニット (固定側) FLANGE TYPE SUPPORT UNIT (FIXED SIDE)

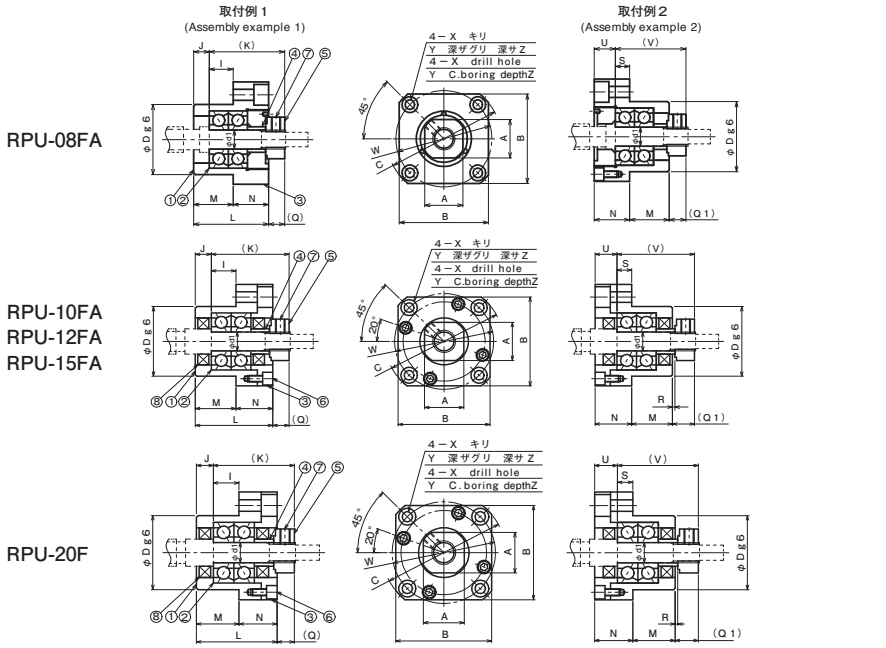

形式 Type	d <sub>i</sub>	L	M	N	D	A	B	C	取付例1 Assembly example 1		取付例2 Assembly example 2		W	X	Y	Z	使用軸受 Bearing No.	ロックナット ねじ寸法 Lock nut					
									Q	I	J	K							Q <sub>1</sub>	R	S	U	
RPU-08FA	8	23	14	9	28	13	35	43	4	10	4	23	5.5	—	4	5	23.5	35	3.4	6.5	4	708ADFP5	M8×0.75
RPU-10FA	10	27	17	10	34	17	42	52	6.5	12	5	28.5	7.5	0.5	4	6	28.5	42	4.5	8	4	7000ADFP5	M10×0.75
RPU-12FA	12	27	17	10	36	19	44	54	7.5	12	5	29.5	8.5	0.5	4	6	29.5	44	4.5	8	4	7001ADFP5	M12×1.0
RPU-15FA	15	32	17	15	40	22	52	63	10	11	6	36	12	4	7	8	36	50	5.5	9.5	6	7002ADFP5	M15×1.0
RPU-20F	20	52	30	22	57	30	68	85	10	20	10	52	14	1	8	14	52	70	6.6	11	10	7204ADFC8P5	M20×1.0

- サポートユニットは予圧調整してありますので分解しないでください。
- ベアリングは適量のグリスを注入してありますのでそのまま使用できます。
- ロックナットを締め付け後、ビス穴に砲金コマを入れて、セットスクリューを軽く締め付けて下さい。

部番	部品名	個数	備考
1	ハウジング	1	
2	ベアリング	1セット	
3	押えブタ	1	
4	スペーサ	2	RPU-20F スペーサ1個
5	ロックナット	1	
6	押えねじ	4	RPU-08FA~15FA 六角穴付き皿ボルト RPU-20F 六角穴付きボルト
7	セットスクリュー	1	
8	オイルシール	2	RPU-08FAはなし

- Never disassemble the support unit as it is an integrated assembly and pre-load adjusted.
- Grease is packed in the support unit.
- Tighten the lock nut. Then tighten lightly the set screw after inserting a brass piece in the screw hole.

part no.	part name	q'ty	remarks
1	Housing	1	
2	Bearing	1set	
3	Plate	1	
4	Spacer	2	RPU-20F Spacer 1pc
5	Lock nut	1	
6	Screw thread	4	RPU-08FA~15FA Hexagon socket head cap machine screw RPU-20F Hexagon socket head cap screw
7	Set screw	1	
8	Oil seal	2	Except RPU-08FA

# 角形サポートユニット (固定側) SQUARE TYPE SUPPORT UNIT (FIXED SIDE)

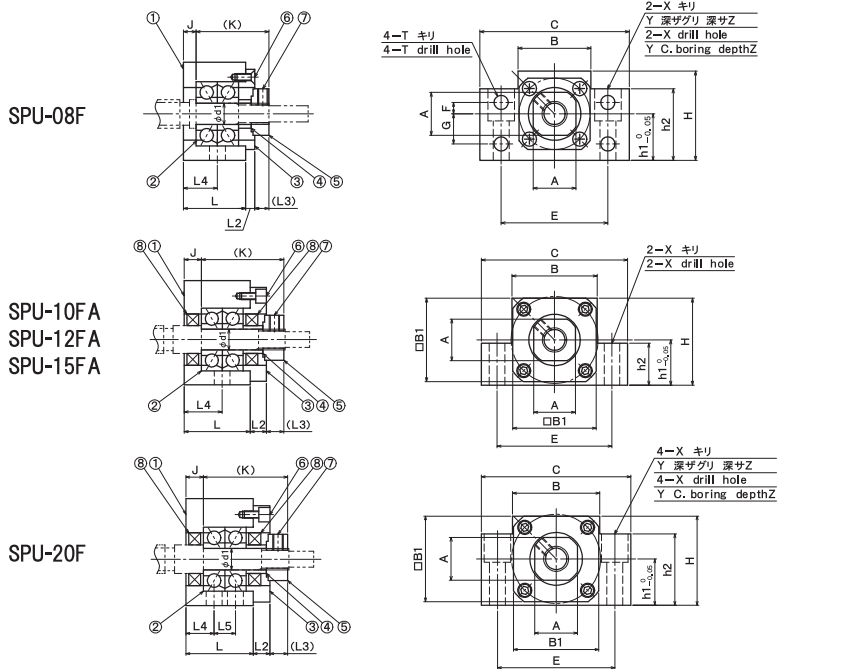

形式 Type	d <sub>i</sub>	L	L <sub>2</sub>	L <sub>3</sub>	L <sub>4</sub>	L <sub>5</sub>	C	H	h <sub>1</sub>	h <sub>2</sub>	A	B	B <sub>1</sub>	E	F	G	J	K	T	X	Y	Z	使用軸受 Bearing No.	ロックナット ねじ寸法 Lock nut	
																									4
SPU-08F	8	20	3	4	10	—	52	32	17	26	13	25	25	38	—	—	—	—	—	—	—	—	—	708ADFC8P5	M8×0.75
SPU-10FA	10	24	6	4.5	12	—	70	43	25	24	17	36	34	52	—	—	6	28.5	—	—	9	—	—	7000ADFP5	M10×0.75
SPU-12FA	12	24	6	5.5	12	—	70	43	25	24	19	36	34	52	—	—	6	29.5	—	—	9	—	—	7001ADFP5	M12×1.0
SPU-15FA	15	25	6	10	12.5	—	80	50	30	25	22	41	38	60	—	—	5	36	—	—	11	—	—	7002ADFP5	M15×1.0
SPU-20F	20	42	10	10	10	—	22	95	58	30	45	30	56	75	—	—	10	52	—	—	11	17	15	7204ADFC8P5	M20×1.0

- サポートユニットは予圧調整してありますので分解しないでください。
- ベアリングは適量のグリスを注入してありますのでそのまま使用できます。
- ロックナットを締め付け後、ビス穴に砲金コマを入れて、セットスクリューを軽く締め付けて下さい。

部番	部品名	個数	備考
1	ハウジング	1	
2	ベアリング	1セット	
3	押えブタ	1	
4	スペーサ	2	SPU-08F・20F スペーサ1個
5	ロックナット	1	
6	押えねじ	4	SPU-08F 皿小ねじ SPU-10FA~15FA 六角穴付き皿ボルト SPU-20F 六角穴付きボルト
7	セットスクリュー	1	
8	オイルシール	2	SPU-08Fはなし

- Never disassemble the support unit as it is an integrated assembly and pre-load adjusted.
- Grease is packed in the support unit.
- Tighten the lock nut. Then tighten lightly the set screw after inserting a brass piece in the screw hole.

part no.	part name	q'ty	remarks
1	Housing	1	
2	Bearing	1set	
3	Plate	1	
4	Spacer	2	SPU-08F・20F Spacer 1pc
5	Lock nut	1	
6	Screw thread	4	SPU-08F Machine screw SPU-10FA~15FA Hexagon socket head cap machine screw SPU-20F Hexagon socket head cap screw
7	Set screw	1	
8	Oil seal	2	Except SPU-08F

# 丸形サポートユニット (支持側) FLANGE TYPE SUPPORT UNIT (SUPPORT SIDE)

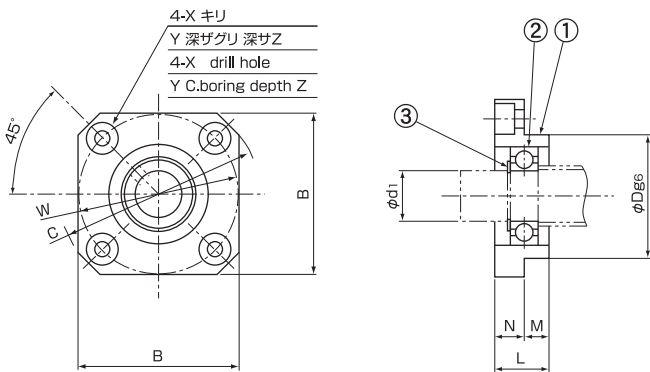

部 番	部品名	個 数	part no.	part name	q'ty
1	ハウジング	1	1	Housing	1
2	ベアリング	1	2	Bearing	1
3	止め輪	1	3	Snap ring	1

単位:mm unit:mm

形 式 Type	d <sub>1</sub>	L	M	N	D	B	C	W	X	Y	Z	使用軸受 Bearing No.	使用止め輪 Snap ring
RPU-08S	6	10	4	6	22	28	36	28	3.4	6.5	3	606ZZ	C6
RPU-10S	8	12	5	7	28	35	43	35	3.4	6.5	3	608ZZ	C8
RPU-12S	10	15	8	7	34	42	52	42	4.5	8	4	6000ZZ	C10
RPU-15S	15	17	8	9	40	52	63	50	5.5	9.5	5.5	6002ZZ	C15
RPU-20S	20	20	9	11	57	68	85	70	6.6	11	6.5	6204ZZ	C20

# 角形サポートユニット (支持側) SQUARE TYPE SUPPORT UNIT (SUPPORT SIDE)

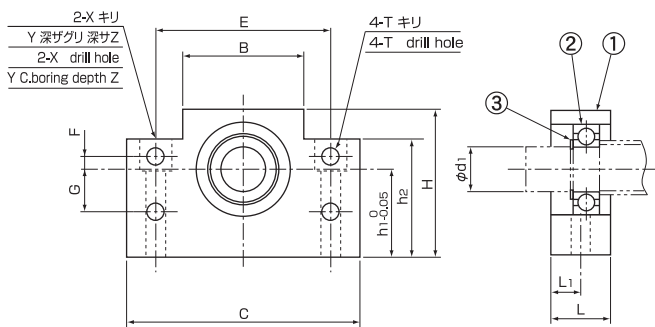

部 番	部品名	個 数	part no.	part name	q'ty
1	ハウジング	1	1	Housing	1
2	ベアリング	1	2	Bearing	1
3	止め輪	1	3	Snap ring	1

単位:mm unit:mm

形 式 Type	d <sub>1</sub>	L	L <sub>1</sub>	C	H	h <sub>1</sub>	h <sub>2</sub>	B	E	F	G	T	X	Y	Z	使用軸受 Bearing No.	使用止め輪 Snap ring
SPU-08S	6	15	7.5	52	32	17	26	25	38	4	10	5.5	6.6	11	12	606ZZ	C6
SPU-10S	8	20	10	70	43	25	35	36	52	4	15	6.6	9	14	11	608ZZ	C8
SPU-12S	10	20	10	70	43	25	35	36	52	4	15	6.6	9	14	11	6000ZZ	C10
SPU-15S	15	20	10	80	50	30	40	41	60	4	15	6.6	9	14	11	6002ZZ	C15
SPU-20S	20	26	13	95	58	30	45	56	75	—	—	—	11	17	15	6204ZZ	C20

# ロックナット LOCK NUT

## Pシリーズ [P series]

砲金コマはナットに内蔵されていますので、ナットを締付け後、固定ねじ2ヶ所を均等に締めて下さい。  
As the brass piece is put in the nut, after tightening the nut, tighten the two fixing screws evenly.

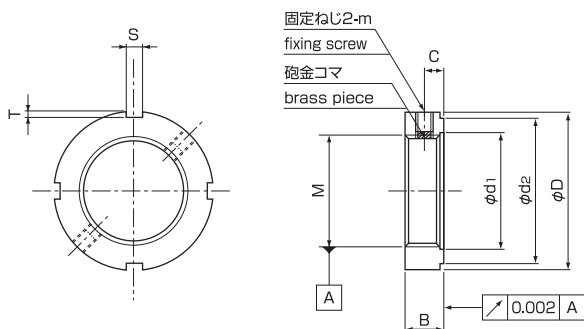

単位:mm unit:mm

形 式 Type	M	D	d <sub>1</sub>	d <sub>2</sub>	B	C	S	T	m
PL-06	M6×0.5	16	7	12	8	4	3	2	M4
PL-08	M8×0.75	16	9	11					
PL-10	M10×0.75	18	11	13					
PL-12	M12×1.0	22	13	18					
PL-15	M15×1.0	25	16	21	10	5	4	M5	
PL-17	M17×1.0	28	18	23					
PL-20	M20×1.0	32	21	27	12	6	5	M6	
PL-25	M25×1.5	40	26	33					
PL-30	M30×1.5	45	31	40					
PL-35	M35×1.5	52	36	47					

## Nシリーズ [N series]

固定ねじは砲金コマを入れてから軽く締めて下さい。  
Tighten the fixing screw lightly after putting in the brass piece.

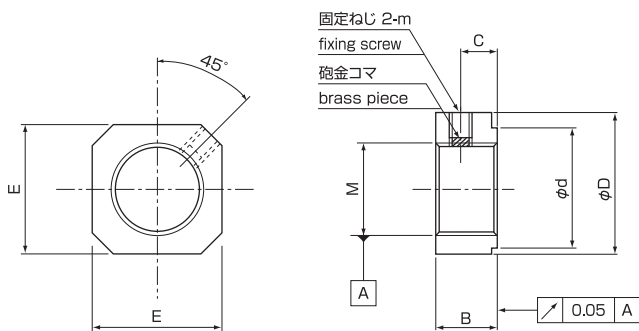

単位:mm unit:mm

形 式 Type	M	D	d	B	C	E	m
NL-06	M6×0.5	14	10	6	3.3	12	M3
NL-08	M8×0.75	16	11	6	3.3	13	
NL-10	M10×0.75	20	16	7	4	17	M4
NL-12	M12×1.0	22	18	7	4	19	
NL-15	M15×1.0	25	20	10	6	21	
NL-20	M20×1.0	35	26	13	8	30	

# BACリードスクリューの構造と特長 CONSTRUCTION OF BAC LEAD SCREW



## 構造 [Construction]

主ナットと予圧リングは円周方向にスリットがありバネ形状になっています。ねじ軸と主ナットはわずかなスキマで噛み合っています。主ナットの外側に予圧リングを入れ、ロックナットを締めることによって、スリットを境に主ナットのねじ部が左右に広がりバックラッシュを調整します。さらにロックナットを締め込むとバネ形状の予圧リングにより定圧予圧がかかりますので、長期間の使用でナットがわずかに摩耗してもスキマを補正する力が働き常にバックラッシュゼロの状態で使用できます。

Radially spread slots of main nut and preload ring are spring shaped. Main nut and shaft are meshed with small clearance. Put preload ring out side of main nut and tighten lock nut, thread of main nut spread out from slit and back lash is compensated. Tightening lock nut further applies constant pressure preloading by spring shaped preload ring. Zero back lash is kept by spring loaded. Construction compensating clearance for long period of use.

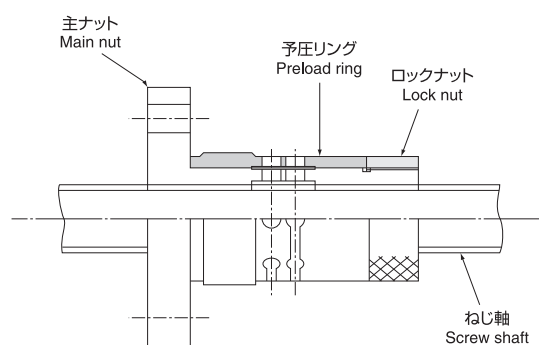

## 特長 [Features]

### ●高い位置決め精度

高精度に加工されたねじと特殊形状のナットを組み合わせ、適正予圧を与えていますのでバックラッシュがなく、高い位置決め精度を有します。また、摩耗により発生するバックラッシュに対しても自己補正する構造になっています。

### ●High positioning accuracy

Suitable preload is applied combination of fine finished screw and special designed nut makes high positioning accuracy with no back lash. Back lash caused by wear is self compensated.

### ●滑らかな回転

ねじ軸と主ナットのねじ面は精密加工されていますので、非常に滑らかな回転が得られます。よって、振動が少なく発熱も最小となっています。

### ●Smooth rotation

Fine finished screw rotate very smooth and minimize vibration and heat.

### ●トルク変動が少ない

定圧予圧方式のため、リード誤差やねじ寸法誤差による回転トルクの変動を小さくすることができます。

### ●Small change in rotating torque

Change of rotating torque caused by lead error or dimension error of screws is reduced by constant pressure preload.

### ●長寿命

ねじ軸は焼入れされ、HRC58～63の硬度を有します。また、主ナットはアルミ青銅鑄物の10倍の耐摩耗性を持つFA381《日立金属(株)》を使用していますので、従来品の送りねじに比べ、寿命が大幅に向上しています。

### ●Long life

Screw shaft is hardened to HRC 58~63. Nut is made by FA381 <Hitach Metal> 10times better wear resistant compared to aluminum bronze costing metal. Life time is improved.....

# BACリードの選定 SELECTION OF BAC LEAD SCREW

## 精度 [Accuracy]

BACリードスクリューの精度はJIS規格の位置決め用ボールねじ(B1192)の精度に準じます。リード精度については表4、5を参照ください。その他の精度については当社精密ボールねじカタログを参照ください。

Accuracy of BAC lead screw is refer to ball screw accuracy JIS B 1192. Lead accracy is shown fig 4,5. Refer ISSOKU ball screw catalog for other items.

表4 代表移動量誤差と変動(許容値) Cumulative representative lead errors and travel variations.(permissible values)

単位:μm unit:μm

ねじ部有効長さ(mm) Effective thread length		C0		C1		C2		C3		C5	
		代表移動量誤差 Cumulative representative lead error	変動 <sup>(1)</sup> Travel variation <sup>(1)</sup>	代表移動量誤差 Cumulative representative lead error	変動 <sup>(1)</sup> Travel variation <sup>(1)</sup>	代表移動量誤差 Cumulative representative lead error	変動 <sup>(1)</sup> Travel variation <sup>(1)</sup>	代表移動量誤差 Cumulative representative lead error	変動 <sup>(1)</sup> Travel variation <sup>(1)</sup>	代表移動量誤差 Cumulative representative lead error	変動 <sup>(1)</sup> Travel variation <sup>(1)</sup>
を越え above	以下 include										
—	125	3	3	3.5	5	5	7	8	8	18	18
125	200	3.5	3	4.5	5	7	7	10	8	20	18
200	315	4	3.5	6	5	8	7	12	8	23	18
315	400	5	3.5	7	5	9	7	13	10	25	20
400	500	6	4	8	5	10	7	15	10	27	20
500	630	6	4	9	6	11	8	16	12	30	23
630	800	7	5	10	7	13	9	18	13	35	25
800	1000	8	6	11	8	15	10	21	15	40	27

注<sup>(1)</sup> ナットの有効移動距離またはねじ軸のねじ部有効長さに対する変動。

Note<sup>(1)</sup> Travel variation in respect to the effective travelling distance of nut or to the effective thread length of screw shaft.

表5 変動(許容値) Travel variations(permissible values)

単位:μm unit:μm

精度等級 Accuracy grade	C0		C1		C2 <sup>(1)</sup>		C3		C5	
項目 Item	変動 Travel variation <sup>(2)</sup>	変動 Travel variation <sup>(3)</sup>	変動 Travel variation <sup>(2)</sup>	変動 Travel variation <sup>(3)</sup>	変動 Travel variation <sup>(2)</sup>	変動 Travel variation <sup>(3)</sup>	変動 Travel variation <sup>(2)</sup>	変動 Travel variation <sup>(3)</sup>	変動 Travel variation <sup>(2)</sup>	変動 Travel variation <sup>(3)</sup>
許容値 Permissible value	3.5	3	5	4	6	5	8	6	18	8

注<sup>(1)</sup> C2級は当社規格。

<sup>(2)</sup> ねじ軸のねじ部有効長さの間に任意にとった300mmに対する変動。

<sup>(3)</sup> ねじ軸のねじ部有効長さの間の1回転(2π rad)に対する変動。

Note<sup>(1)</sup> grade C2 is ISSOKU standard.

Note<sup>(2)</sup> Travel variation in respect to 300mm taken arbitrarily within the effective thread length of screw shaft.

Note<sup>(3)</sup> Travel variation in respect to one arbitrary revolution (2π rad) within the effective thread length of screw shaft.

## ねじ軸の製作範囲 [Production range of screw shaft]

標準の作業で製作できるねじ軸の最大長さを表6に示します。

製作範囲を超える場合は弊社までご相談ください。

Maximum length with standard procedure is shown in fig 6.

Please ask for out of this range.

表6 ねじ軸の製作範囲 Production range of screw shaft

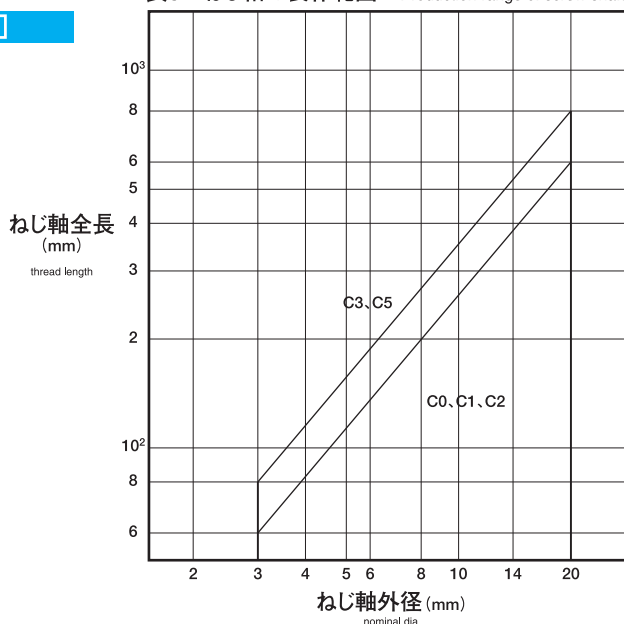

# BACリードスクリューの仕様 SPECIFICATIONS OF BAC LEAD SCREW

## 設計上の注意 [Cautions of designing]

### ●軸端形状

ねじ軸の軸端形状を設計されるときは、軸端の片側をねじ軸の谷径寸法（ナット寸法表の $d_r$ 寸法）以下にしてください。（図1参照）

### ●主負荷方向

BACリードスクリューは、定圧予圧方式を採用していますので、その特性上外部からの主負荷は図2のように矢印の方向で受けるようにしてください。

### ●取り付け回りの設計

BACリードスクリューを装置に取り付ける場合は、ナットをねじ軸から抜かなくても取り付けできる構造にしてください。ナットを抜くと主ナットのスリット部が伸びきってしまい使用不可能になります。どうしてもナットを抜く必要がある場合はあらかじめ当社までご連絡ください。

### ●後加工

納入後、ねじ軸やナットにノックピンなどの後加工がある場合は、その位置と寸法をあらかじめご連絡ください。

### ●ナットのはめあい

BACリードスクリューのナットを相手部品に取り付ける場合は、スキマバメ（完全にアソビをつける）にしてください。ナットの外径部をシマリバメにしたラジアル荷重がかかると、円滑な作動をしなくなる場合があります。（図3参照）

### ●潤滑

BACリードスクリューの潤滑は、擺動面用のグリースまたはオイルを使用してください。オイル潤滑の場合は特に油膜切れにならないように注意してください。

当社では標準として、二硫化モリブデン入りのグリースを使用していますので、長期間にわたり摩耗無く使用できます。特殊な条件で使用する場合は、指定潤滑剤がある場合はご連絡ください。

### ●Shaft ends

When designing the screw shaft, make one side of shaft end smaller than minor diameter of thread.

### ●Main load direction

Because of constant pressure preloading, main load should apply direction shown in fig 2.

### ●Designing of nut mounting

Please design mounting no need of removing nut from shaft. Spring loaded main nut is stretched and damaged by removing nut from shaft. If removing is not avoided. Please ask previously.

### ●Additional machining

If additional machining such as dowel pin etc. Inform position and size previously.

### ●Fitting of nut

Mount nut of BAC lead screw, with loose fit (completely loose). Radial loading or tight fit for nut will cause unsmoothness.

### ●Lubrication

Lubricate BAC lead screw with grease or oil. If oil lubrication is used, be careful to running out of oil. Molybdenum grease as our standard is long period of using. If BAC lead screw is used under special environment or any other lubrication way, Please inform us about it.



図1 軸端形状  
Fig.1 Shaft end



図2 主負荷方向  
Fig.2 Main load direction

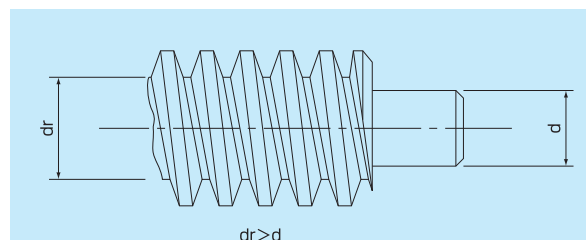

図3 ナットのはめあい  
Fig.3 Fitting of nut

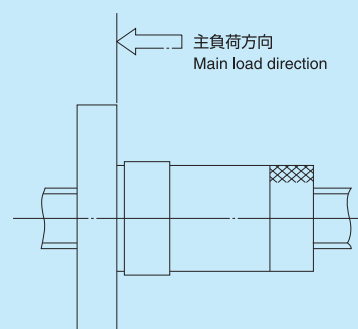

# BACリードスクリューの呼び方 IDENTIFICATION NUMBERS OF BAC LEAD SCREW

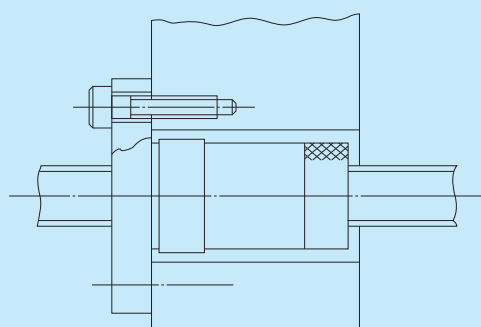
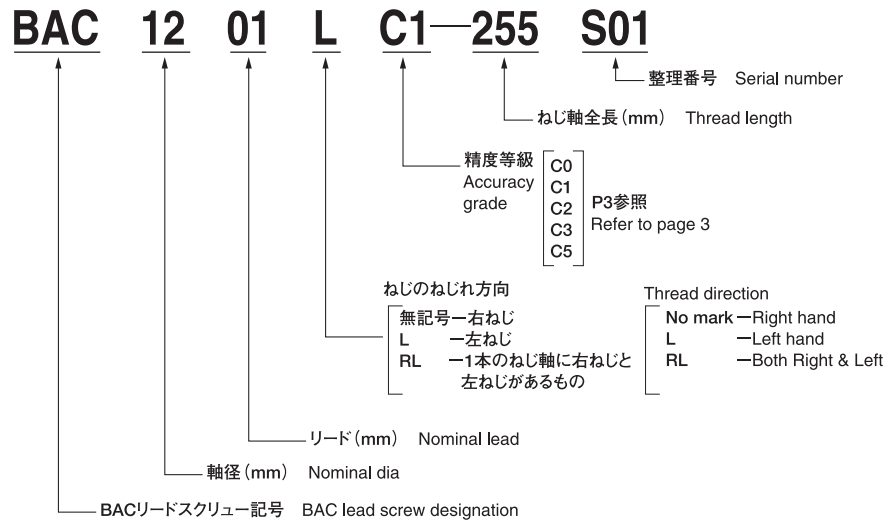

# BACリードスクリューナット寸法表 DIMENSIONS OF NUT

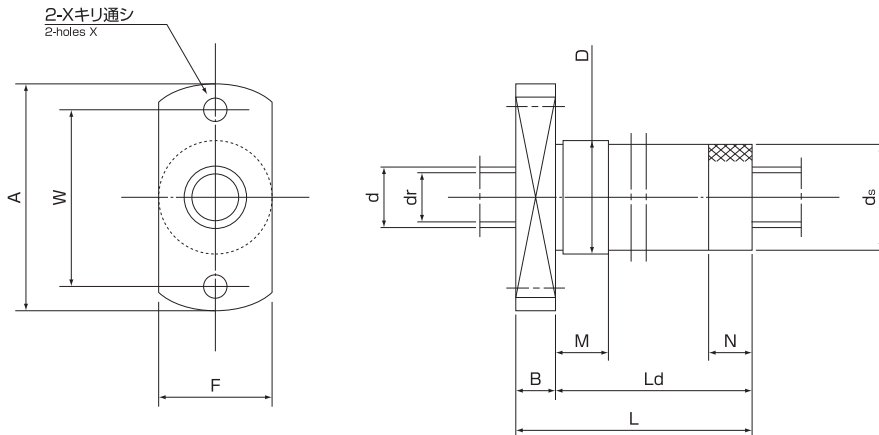

単位:mm Unit:mm

ナット呼び番号 Nut number	ねじ軸外径d Major dia. of shaft	リード(ℓ) Nominal lead	ねじ軸径dr Root dia. of shaft	ナット寸法 Nut dimensions																				
				A	W	D	Ds	F	L	B	Ld	M	N	X										
BAC 0300.3	3	0.3	2.6	19	14	8	7.5	8	17	3	14	3	4	2.9										
BAC 0300.5		0.5	2.3																					
BAC 0400.3	4	0.3	3.6	20	15	9	8.5	9	18	3	15	3	4	2.9										
BAC 0400.5		0.5	3.3																					
BAC 0401		1	3.1												21	16	10	9.5	10	19	16	4		
BAC 0500.3	5	0.3	4.6	25	18	10	9.5	10	20	4	16	4	4	3.4										
BAC 0500.5		0.5	4.3																					
BAC 0501		1	4.1												26	19	11	10.5	11	22	18	5	5	
BAC 0501.5		1.5	3.7												27	20	12	11.5	12	25	21	5	5	
BAC 0502		2	3.7												27	20	12	11.5	12	25	21	5	5	
BAC 0600.5	6	0.5	5.3	26	19	11	10.5	11	22	4	18	5	5	3.4										
BAC 0601		1	5.1												27	20	12	11.5	12	25	21	6		
BAC 0601.5		1.5	4.7												28	21	13	12.5	13	27	4	23	6	5
BAC 0602		2	4.7																					
BAC 0800.5	8	0.5	7.3	29	22	14	13.5	14	24	5	19	5	5	3.4										
BAC 0801		1	6.7																					
BAC 0801.5		1.5	6.2												30	23	15	14.5	15	29	5	24	6	6
BAC 0802		2	6.2																					
BAC 0802.5		2.5	6.2												31	24	16	15.5	16	31	5	26	7	6
BAC 0803		3	6.2																					

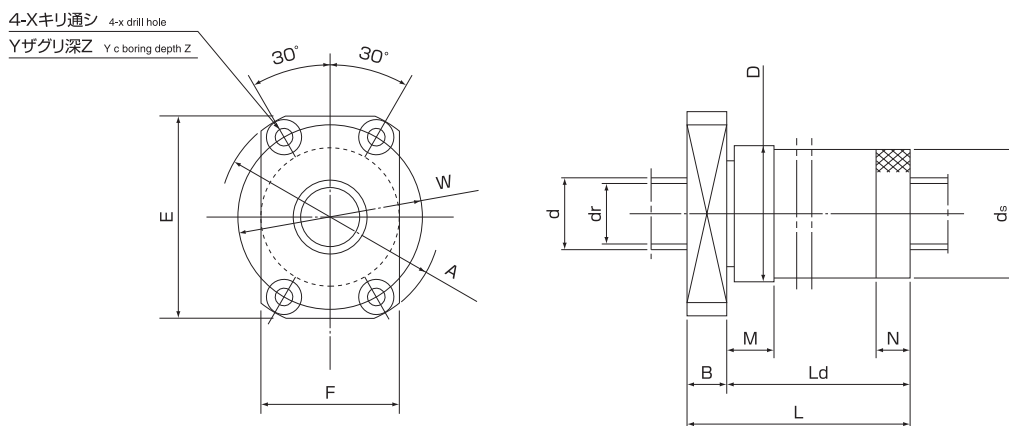

ナット寸法・ねじ軸径・およびリードなどは特殊寸法品・インチサイズ品も製作いたしますので当社までご連絡ください。

Non standard size, inch size of nut, dia, lead can be made.

単位:mm Unit:mm

ナット呼び番号 Nut number	ねじ軸外径d Major dia. of shaft	リード(ℓ) Nominal lead	ねじ軸径dr Root dia. of shaft	ナット寸法 Nut dimensions																							
				A	W	D	Ds	E	F	L	B	Ld	M	N	X	Y	Z										
BAC 1000.5	10	0.5	9.3	33	25	17	16.5	30	21	29	6	23	5	6	3.4	6.5	3.3										
BAC 1001		1	8.7																								
BAC 1001.5		1.5	8.2																								
BAC 1002		2	8.2																								
BAC 1002.5		2.5	8.2	35	27	19	18	32	22	32		26	6	7													
BAC 1003		3	7.5																								
BAC 1004		4	7.5	42	32	22	21	38	26	42		8	34	8				8	4.5	8	4.4						
BAC 1201		1	10.7																			41	31	21	20	36	25
BAC 1201.5	1.5	10.2																									
BAC 1202	2	9.5																									
BAC 1202.5	2.5	9.5																									
BAC 1203	3	9.5	43	33	23	22	39	27	41	8	33	8	8	4.5	8	4.4											
BAC 1204	4	8.5																									
BAC 1205	5	8.5	44	34	24	23	40	27	50	10	40	10	10														
BAC 1401	1	12.7															43	33	23	22	39						
BAC 1401.5	1.5	12.2																									
BAC 1402	2	11.5																									
BAC 1402.5	2.5	11																									
BAC 1403	3	10.5	45	35	25	24	41	28	41	8	33	8	5.5									9.5	4.4				
BAC 1404	4	10.5																									
BAC 1405	5	10.5	49	37	26	25	44	30	50	10	40	10		10													
BAC 1601	1	14.7													49	37								26	25	44	30
BAC 1601.5	1.5	14.2																									
BAC 1602	2	13.5																									
BAC 1602.5	2.5	13																									
BAC 1603	3	12.5	51	39	28	27	46	32	45	8	34	8		5.5			9.5	5.4									
BAC 1604	4	11.5																									
BAC 1605	5	11.5	53	41	30	29	48	32	53	11	42	10	10														
BAC 2001	1	18.7																	55	43	32	31	50				
BAC 2001.5	1.5	18.2																									
BAC 2002	2	17.5																									
BAC 2002.5	2.5	17																									
BAC 2003	3	16.5	57	45	34	33	50	34	48	8	37	10	10		5.5	9.5								5.4			
BAC 2004	4	15.5																									
BAC 2005	5	15.5	59	47	36	35	53	36	55	11	44	12	10														
BAC 2006	6	15.5												59			47	36							35	53	36

※本仕様は改良のため予告なく変更する場合がございます。

直動テーブル [Linear positioning table]

カスタムデザインの専用位置決めユニットから量産品のOEMまで当社の技能と技術を結集して製品化します。

ISSOKU offers various precision devices like custom-made unit for positioning by experienced skills and unique technologies. OEM of mass-production machine parts is also available.

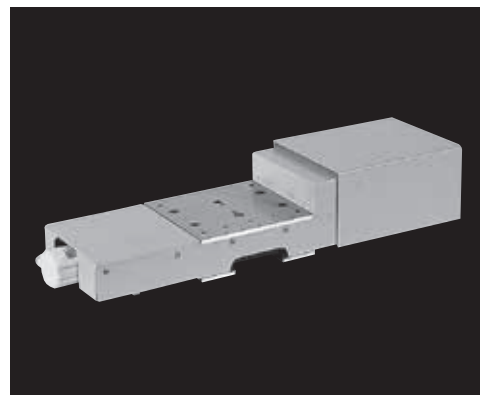
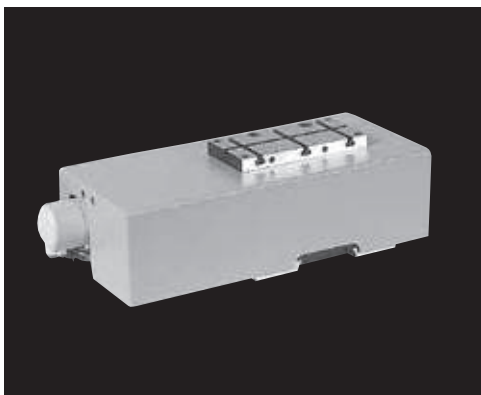

精密スピンドル [Precision spindle]

ベーシックなボールベアリング方式を中心に最新の磁気軸受け方式までカバーします。

ISSOKU's spindle units have wide variation from basic system using ball bearings to improved system using magnetic bearings. They apply to various machines mainly.

