

Anaesthetic and respiratory equipment Gauge for Conical connectors Cones and sockets



Interchangeability of connecting parts of masks connectors and tubing are needed to assure proper assemble of anaesthetic and breathing system. Gauges for testing these connection are used for manufacturing and inspection of equipment and incoming inspection at medical institutions.

■ Advantages

Used for inspection of tapered portion accordance with ISO 5656-1 (JIS T 7201-1). Properly inspect ISO requirements [conical connections need to be secure but nevertheless disconnectable by the operator.].

Precisely finished gauges with lapping process ensure accuracy and quality of connecting medical equipment.

■ Example of use (Plug and Ring test gauges for conical connectors made of materials other than metal.)

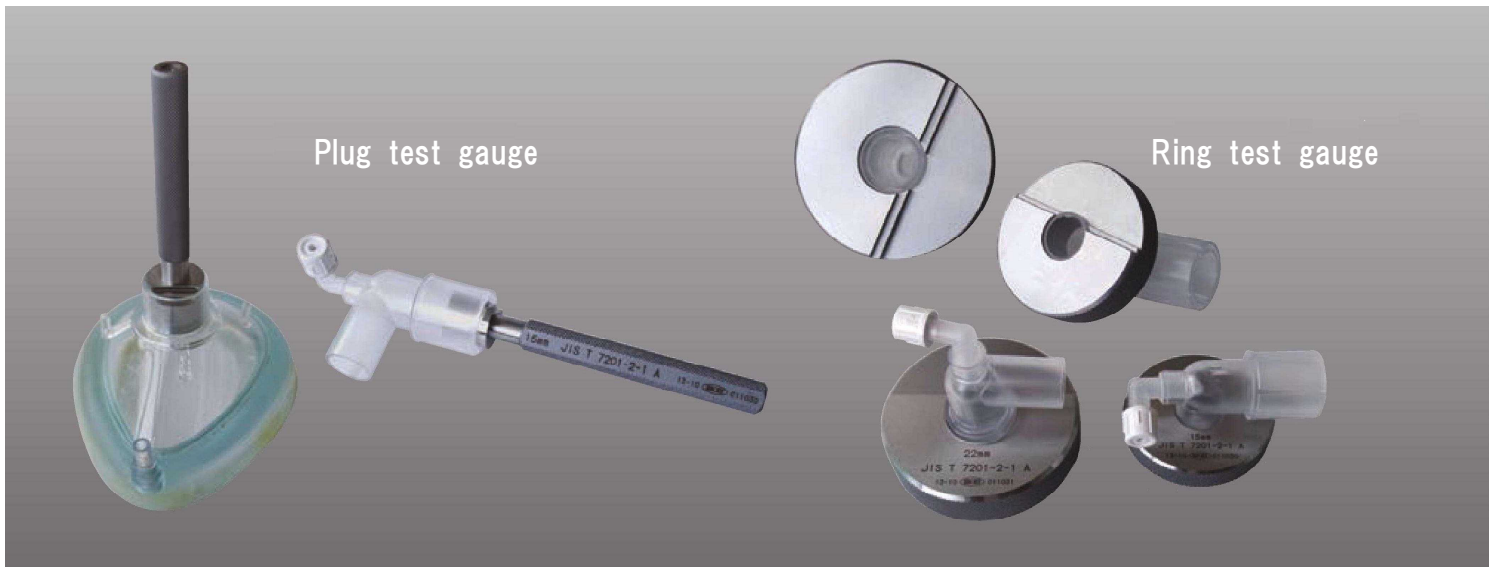

■ Dimension of gauges

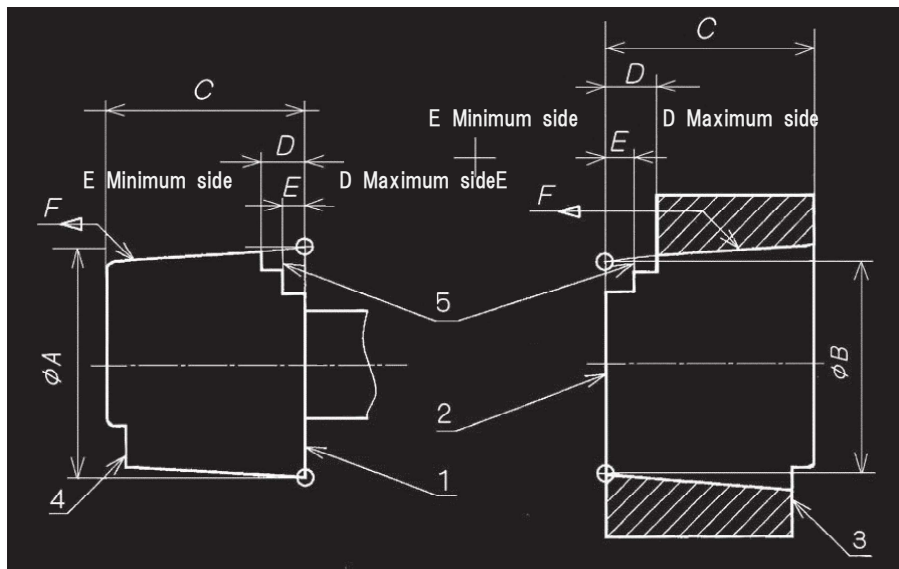

- 1.Surface A
- 2.Surface B
- 3.Step to check position against surface A precisely with matched gauge.
- 4.Step to check position against surface B precisely with matched gauge.
- 5.Reference step

■ Specification

Size of connector	A	B	C	D	E	F	Taper tolerance in diameter per length (mm)
	mm	mm	mm	mm	mm	Taper ratio	
15mm	15.525±0.005	15.525±0.005	14.5±0.005	4.3±0.005	2.2±0.005	1:40	0.025±0.0002
22mm	22.425±0.005	21.94±0.005	19.5±0.005	5.2±0.005	2.2±0.005	1:40	0.025±0.0002
30mm	39.98±0.005	30.12±0.005	15.0±0.005	3.1±0.005	1.6±0.005	1:40	0.050±0.0002

株式会社 第一測範製作所

DAI-ICHI SOKUHAN WORKS CO.
URL <http://www.issoku.jp> E-mail info@issoku.jp



ISO 14001 認証
JQA-EM4941
本社工場



ISO 9001 認証
JQA-2223
登録活動範囲:
*ねじゲージ、丸物ゲージ及び空気マイクロメータの設計・開発、製造及び校正
*ボールねじの設計・開発及び製造

HEAD OFFICE & PLANT:826-2,TSUBONO,OJIYA CITY,NIIGATA PREF.,947-0044
TEL (0258) 84-3911 FAX (0258) 81-2113