

外径測定ヘッド MEASURING HEAD FOR EXTERNAL DIAM.

被測定物をはさむだけで高精度の外径測定ができるはさみ式と測定物を挿入するリング式の2種類が標準化されています。

Two kinds of caliper type and ring type are standardized. It is easy to do precision measurement only to put a workpiece between measuring head (caliper type) or to insert a workpiece into measuring head. (ring type)

はさみ式 No.8310
Caliper type

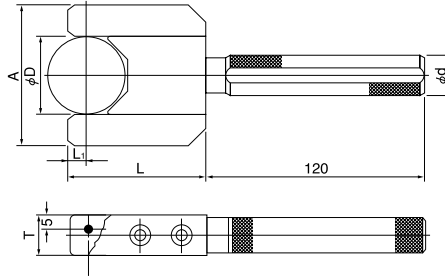
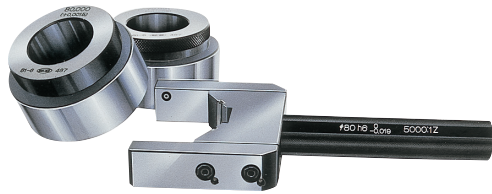

φD	A	L	L ₁	T	φd
5- 10	42	45	6	20	23
10- 12	42	54	8	20	23
12- 15	D+30	54	8	20	23
15- 25	D+30	60	8	20	23
25- 35	D+30	65	8	20	23
35- 50	D+30	69	8	20	23
50- 65	D+30	72	8	22	23
65- 85	D+30	82	8	22	23
85-105	D+30	92	8	25	23
105-125	D+30	102	8	25	23

リング式 No.8300・8302
Ring type

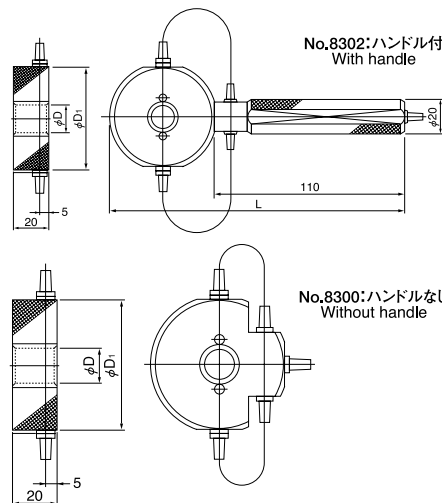

φD	D ₁	L
6-10	50	159
10-20	60	169
20-30	70	179
30-40	80	189
40-50	90	199
50-60	106	215

リング式 No.6300・6303
Ring type

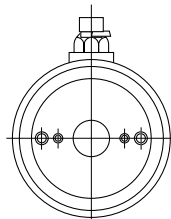
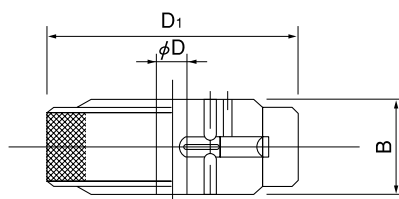

No.6300:対向ノズル
Two measuring nozzles

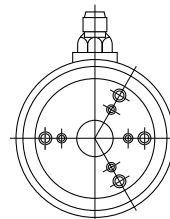

No.6303:3方ノズル
Three measuring nozzles

φD	D ₁	B
8-14	55	18
14-20	62	18
20-26	68	22
26-32	74	22
32-38	80	24
38-45	88	26
45-52	94	28
52-60	102	30
60-68	110	32
68-76	118	34
76-84	125	36
84-92	134	38
92-100	142	40
100-108	150	42
108-116	158	44

(注) No.6300は対向ノズル、No.6303は3方ノズル

Note
No.6300 : two measuring nozzles
No.6303 : three measuring nozzles

- φ8以下のサイズにつきましては、ご相談下さい。
- ハードクロムメッキ、超硬、TiNコーティング製品も製作致します。
- Please ask for φ8 and smaller.
- Measuring head treated hard-chrome plating or TiN coating and material of tungsten carbide measuring head can be manufactured also.